

Westwood UNDERGROUND UTILITY-ELECTRICAL CROSSING **UT06**

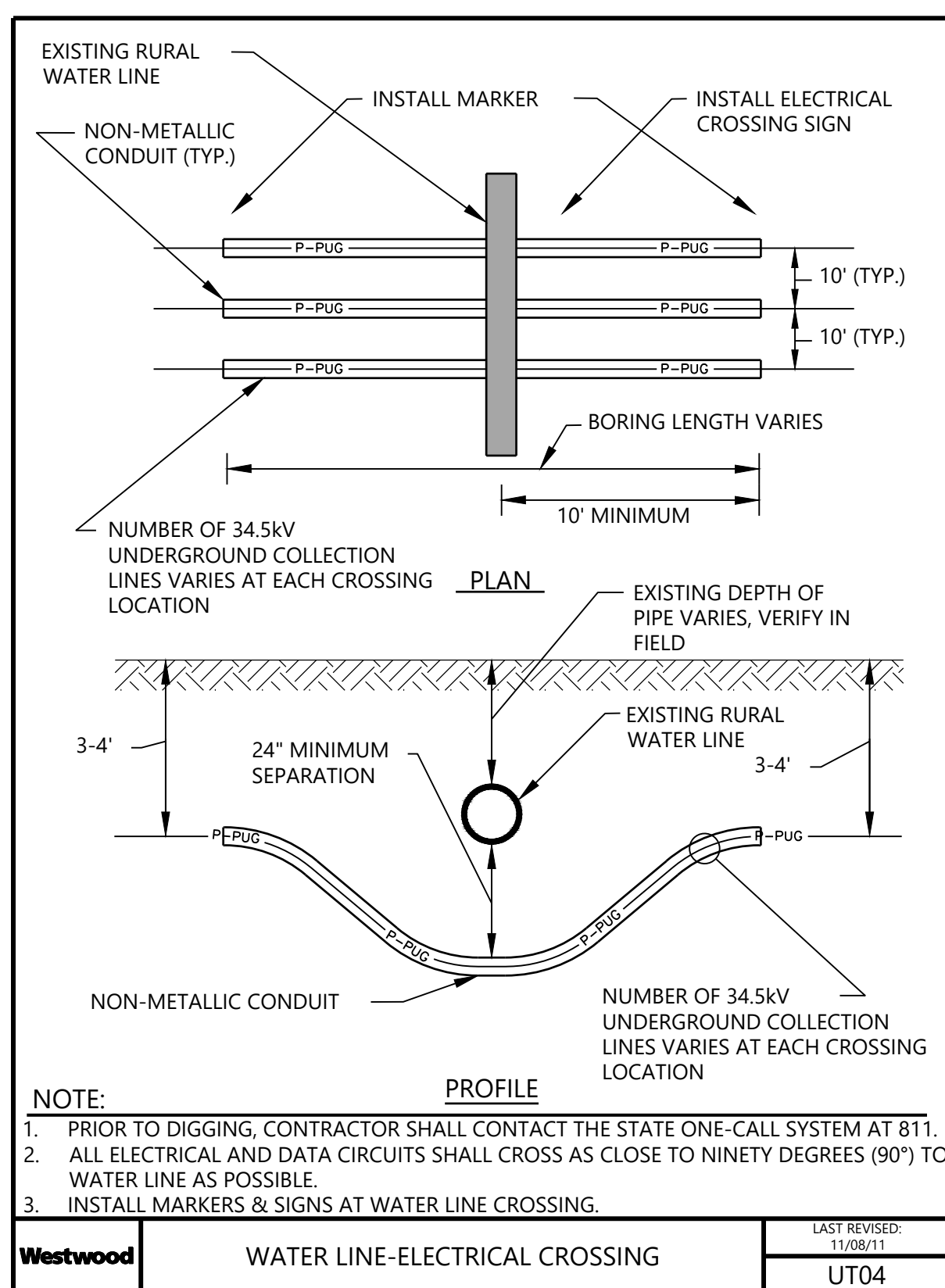

Westwood WATER LINE-ELECTRICAL CROSSING **UT04**

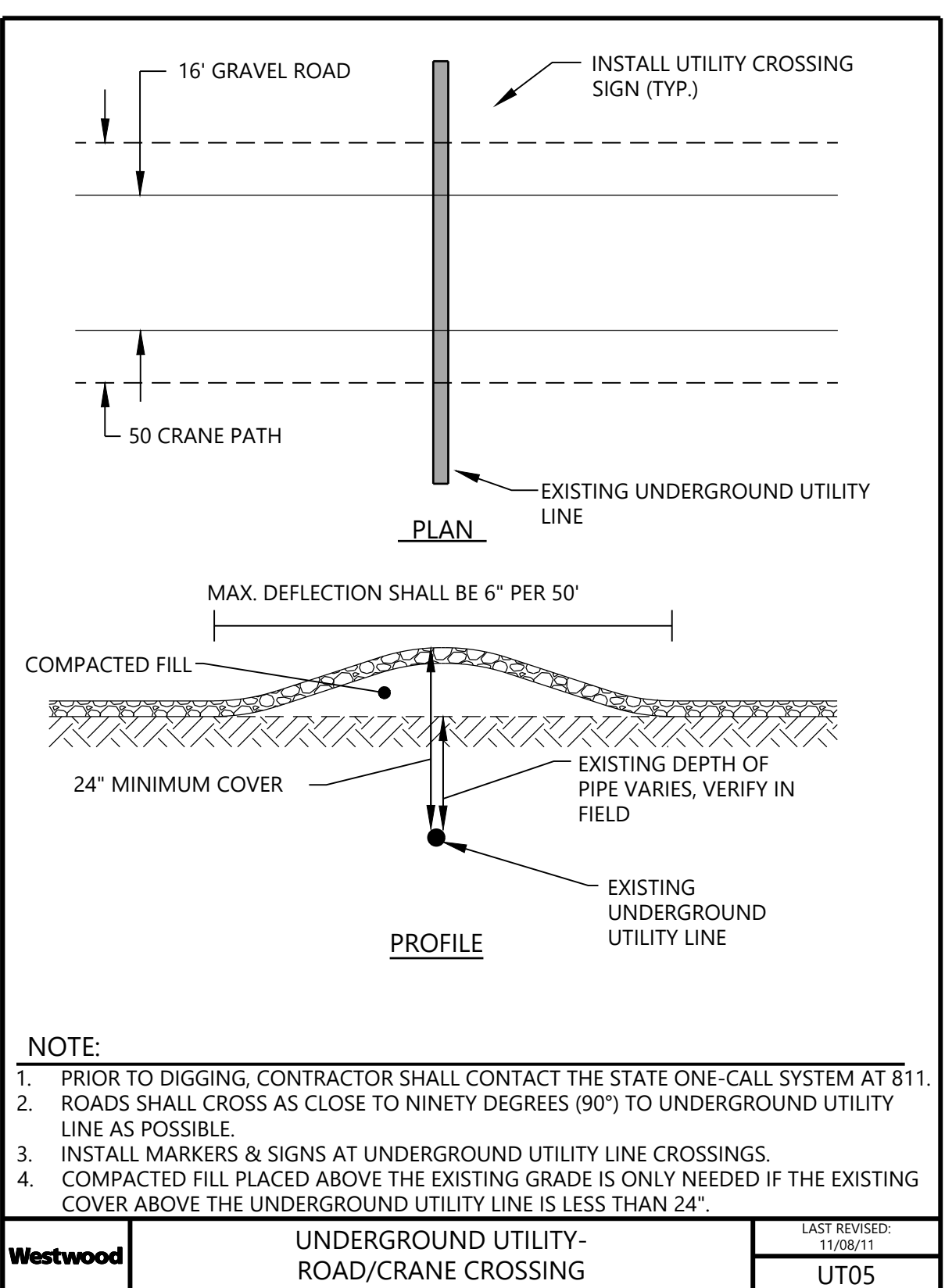

Westwood UNDERGROUND UTILITY-ROAD/Crane CROSSING **UT05**

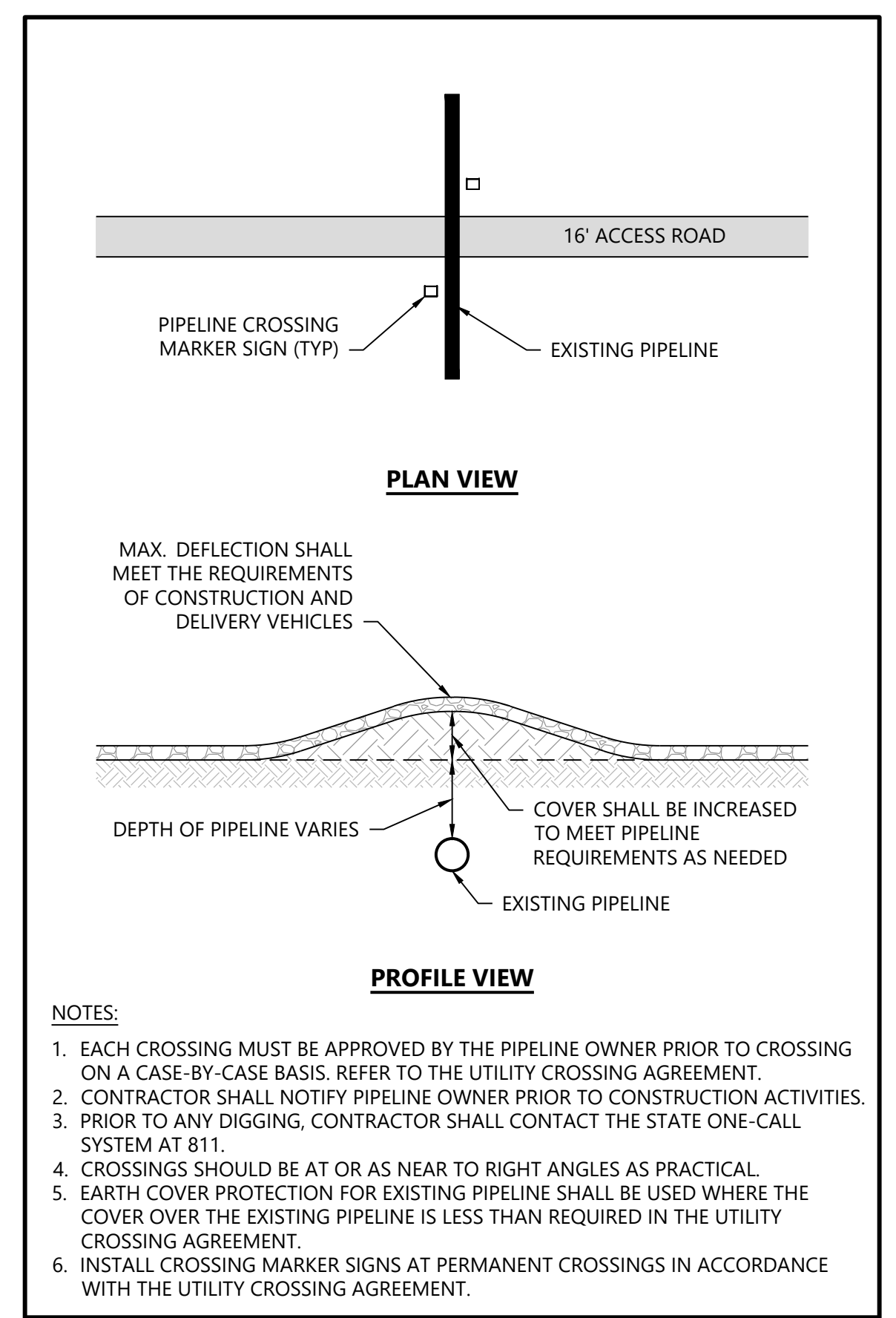

Westwood ACCESS ROAD CROSSING OF EXISTING PIPELINE **UT-01**

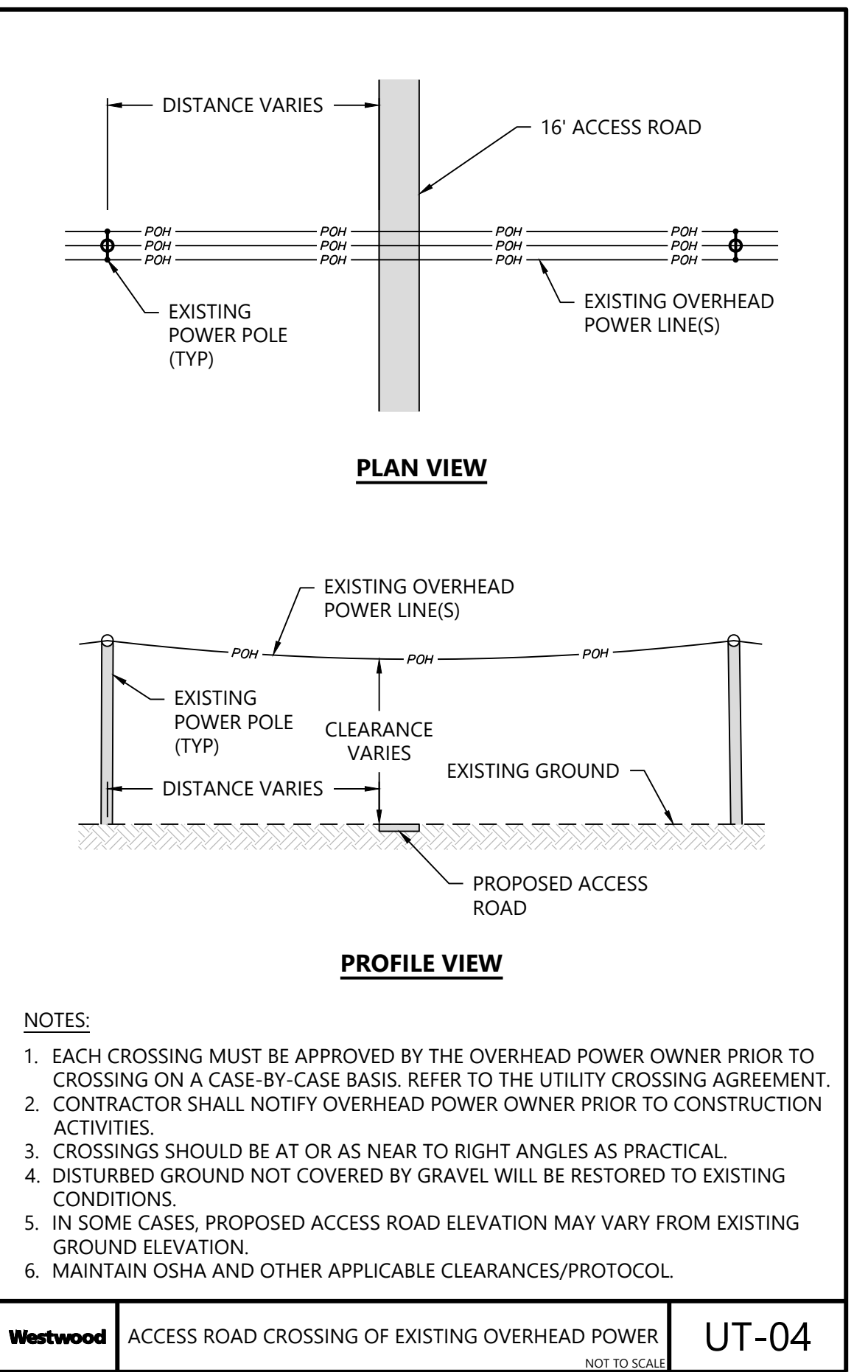

Westwood ACCESS ROAD CROSSING OF EXISTING OVERHEAD POWER **UT-04**

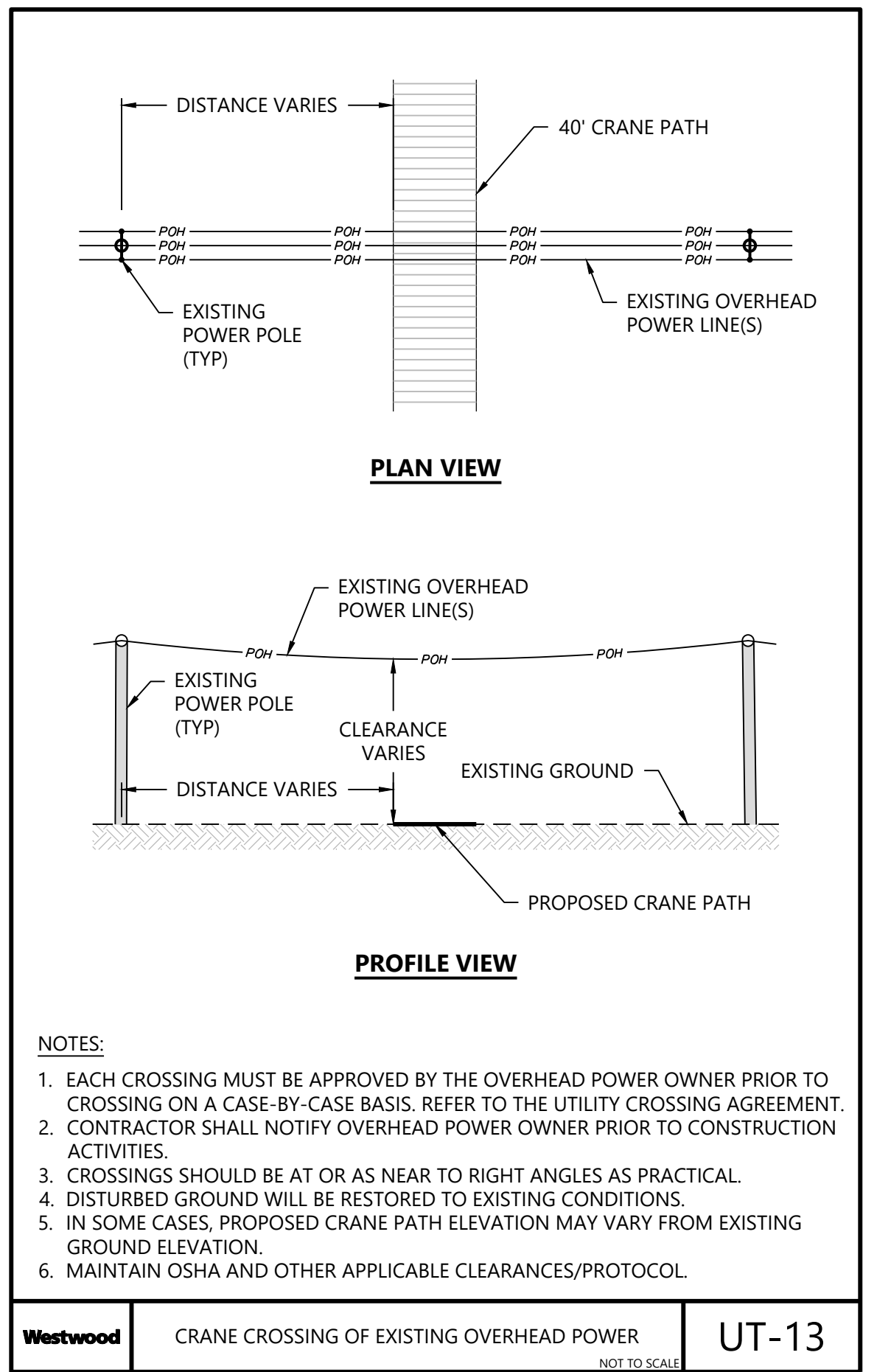

Westwood CRANE CROSSING OF EXISTING OVERHEAD POWER **UT-13**

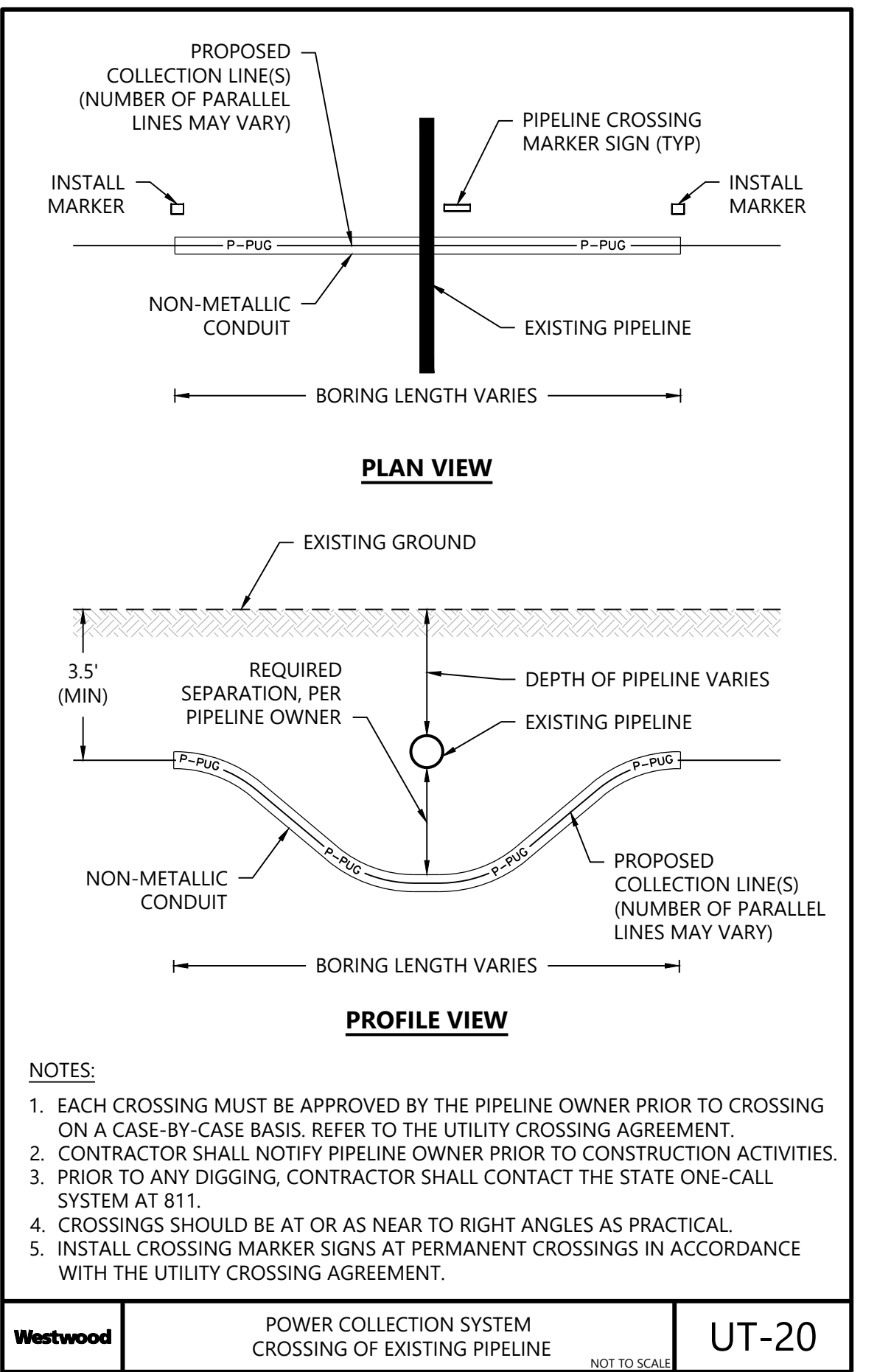

Westwood POWER COLLECTION SYSTEM CROSSING OF EXISTING PIPELINE **UT-20**

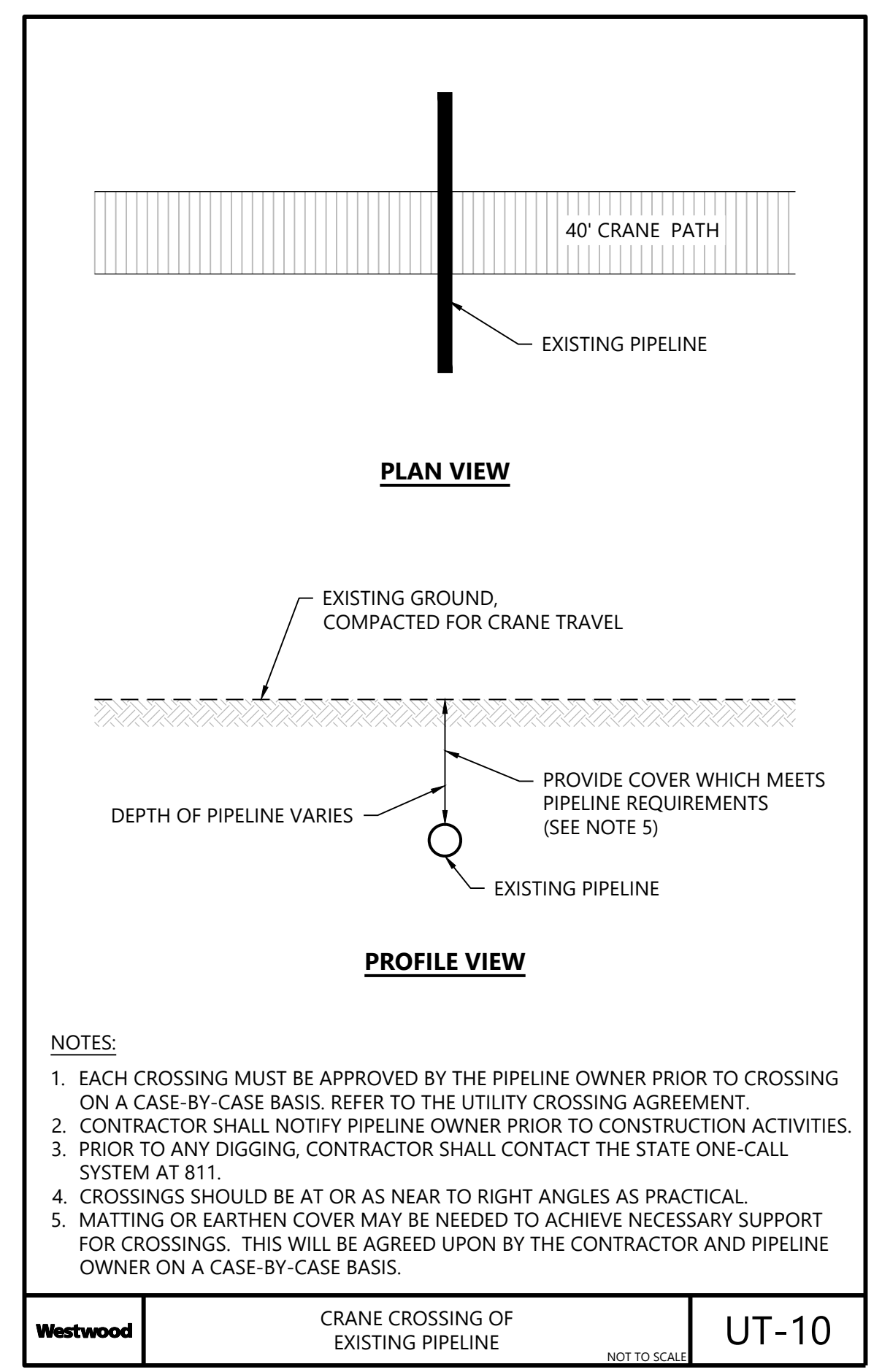

Westwood CRANE CROSSING OF EXISTING PIPELINE **UT-10**

PREPARED FOR:

Hoffman Falls Wind LLC

90 State Street, Suite 700
 Albany, NY 12207

REVISIONS:

#	DATE	COMMENT	BY	CHK	APR
A	08/25/2023	30% CIVIL DESIGN	HR	DK	AL
B	12/29/2023	60% CIVIL DESIGN	HR	HR	AL

Hoffman Falls Wind Project
 Madison County, New York

Construction Details -
 13

ISSUE FOR PERMIT

DATE: 12/29/2023
 SHEET: C712
 REV: B

FIGURE 2.1
 STABILIZED CONSTRUCTION ACCESS

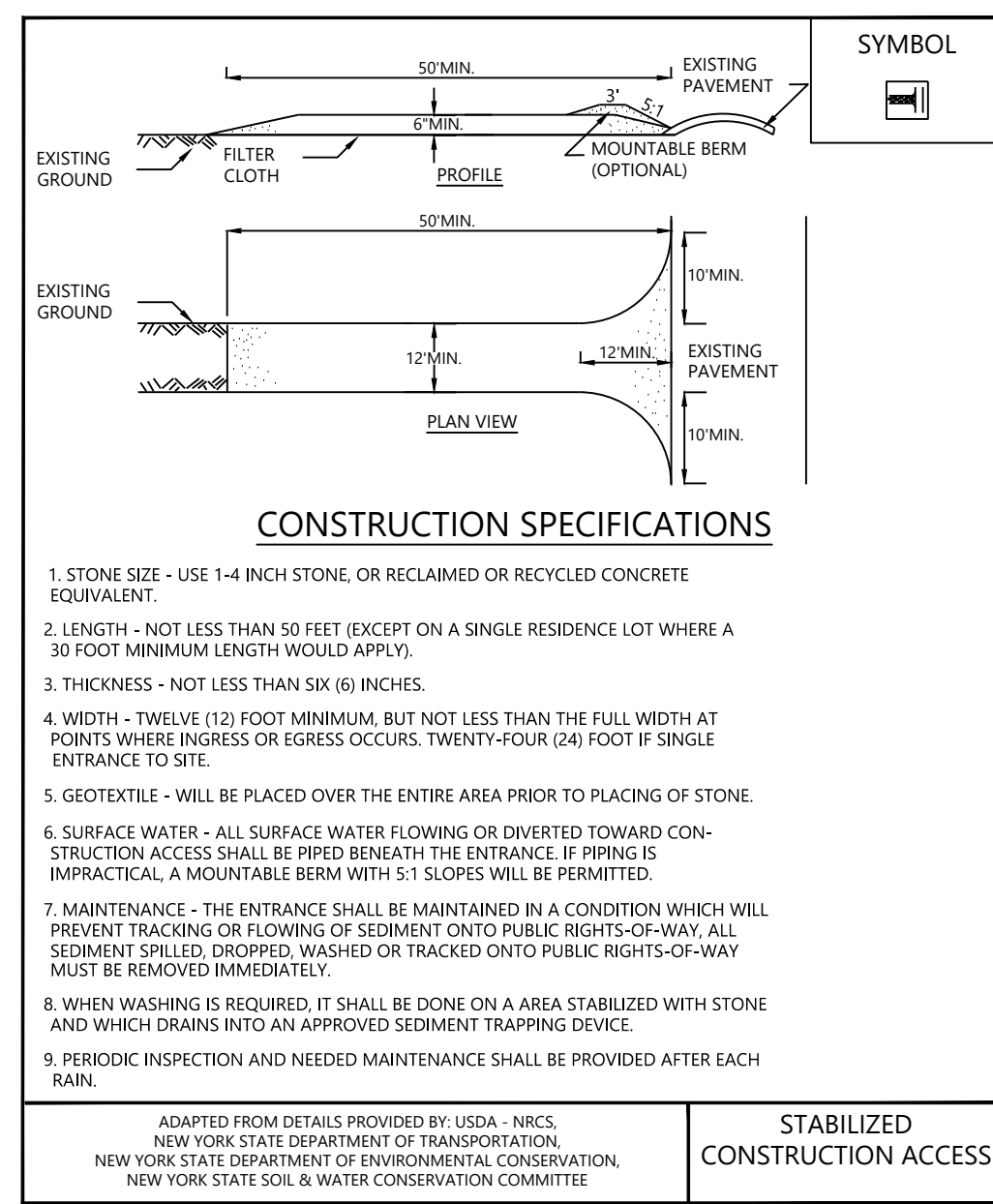

FIGURE 2.2
 TEMPORARY ACCESS BRIDGE

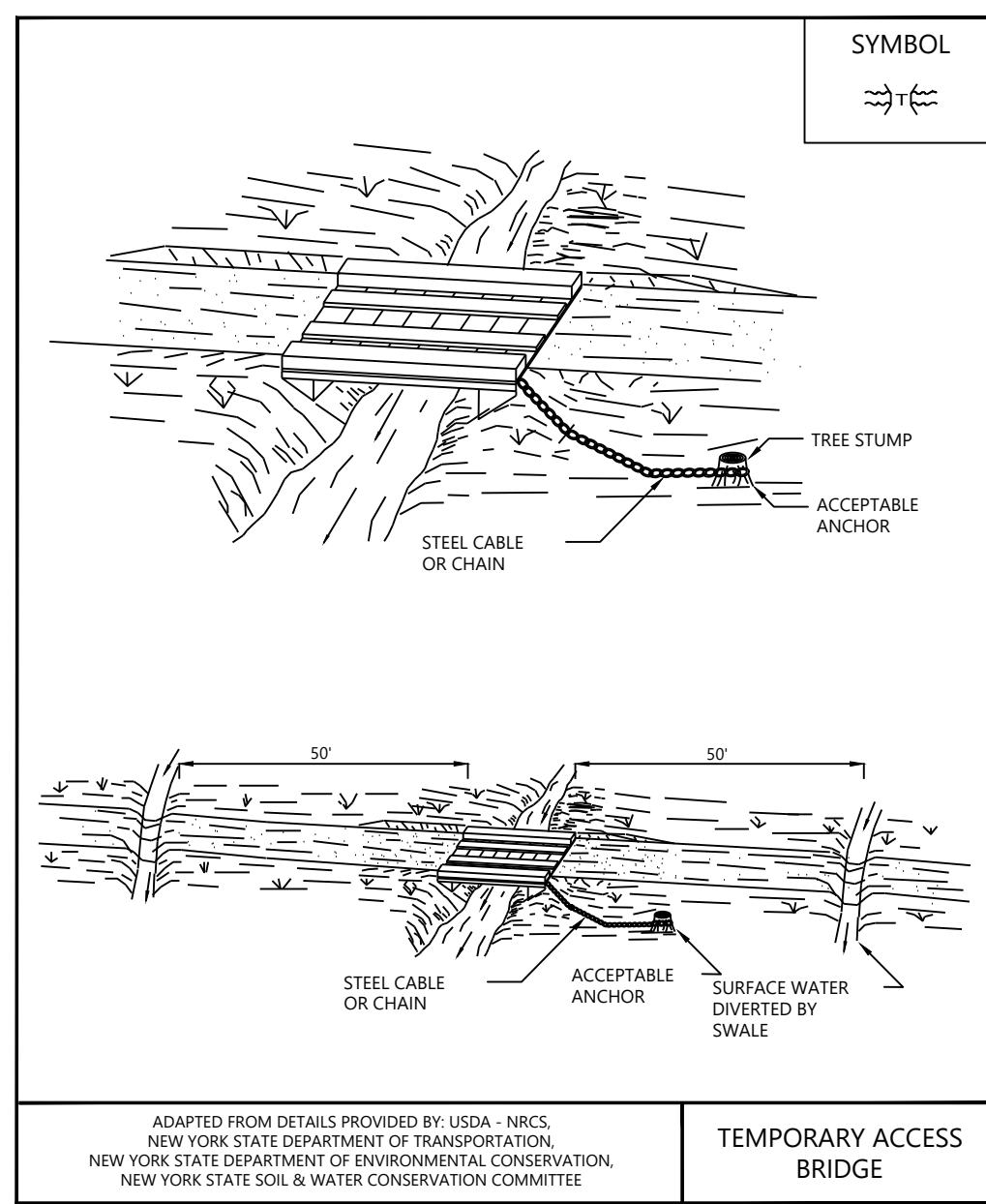

FIGURE 2.3
 TEMPORARY ACCESS CULVERT

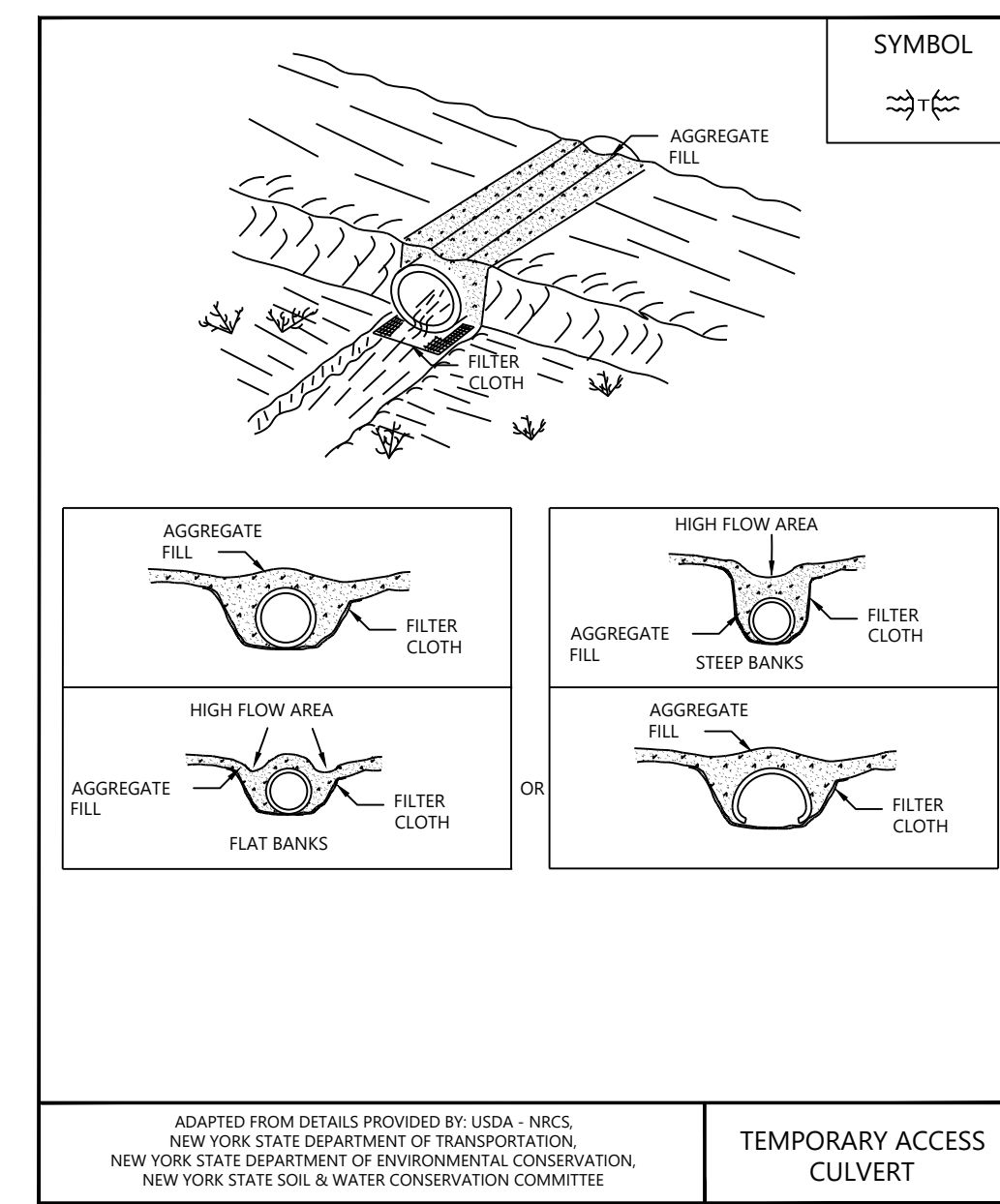

FIGURE 3.1
 STONE CHECK DAM DETAIL

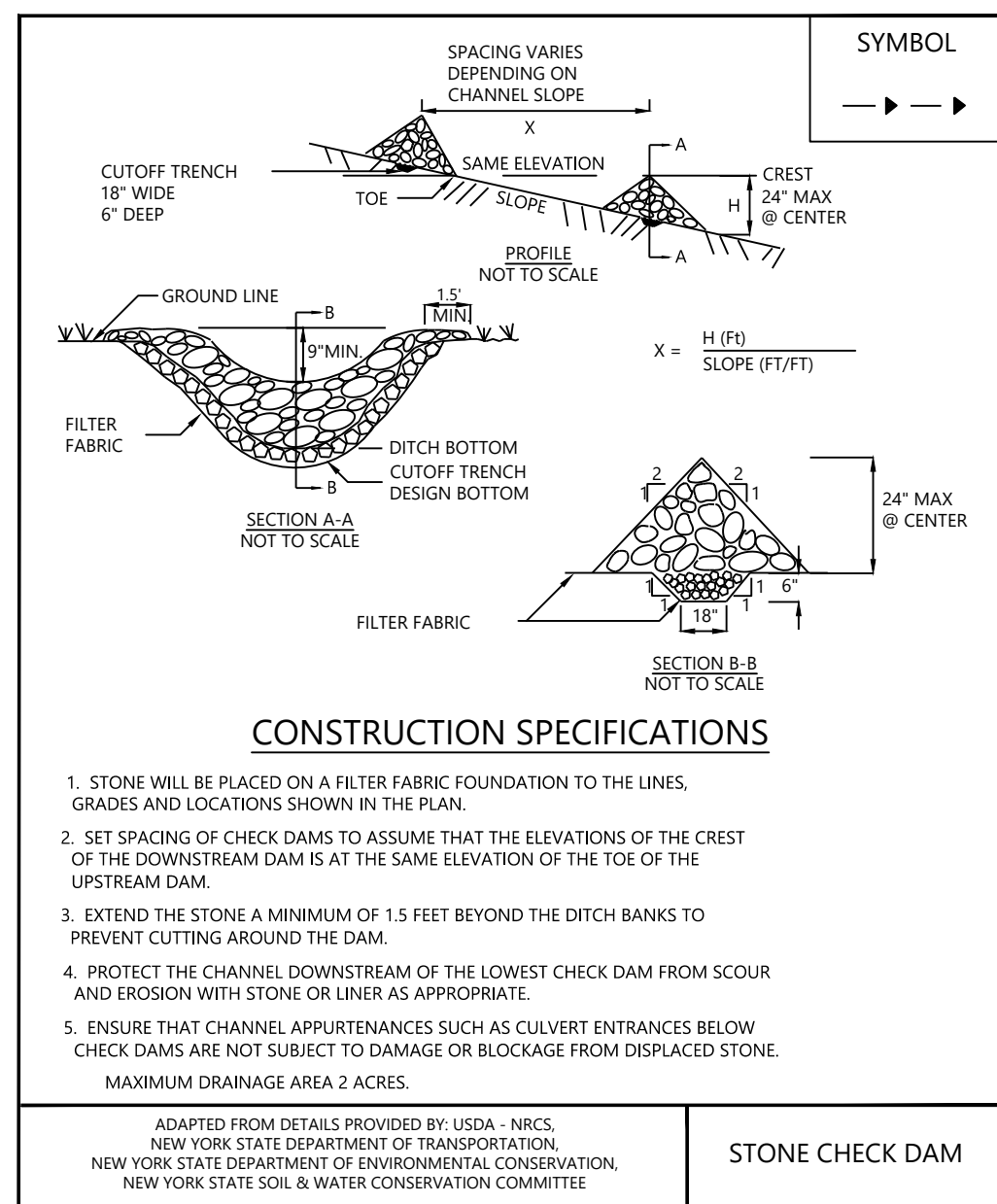

FIGURE 3.2
 CONSTRUCTION DITCH DETAIL

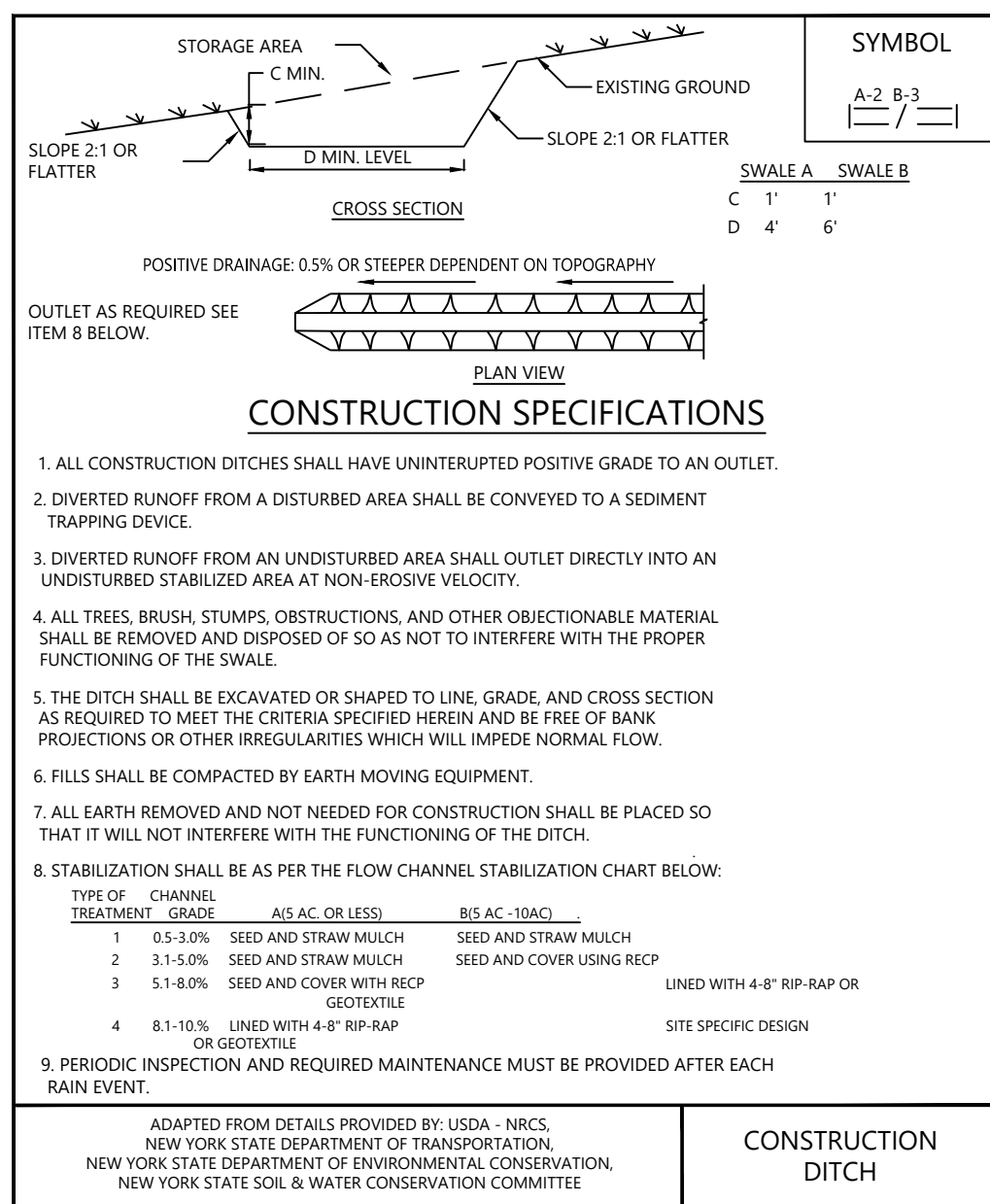
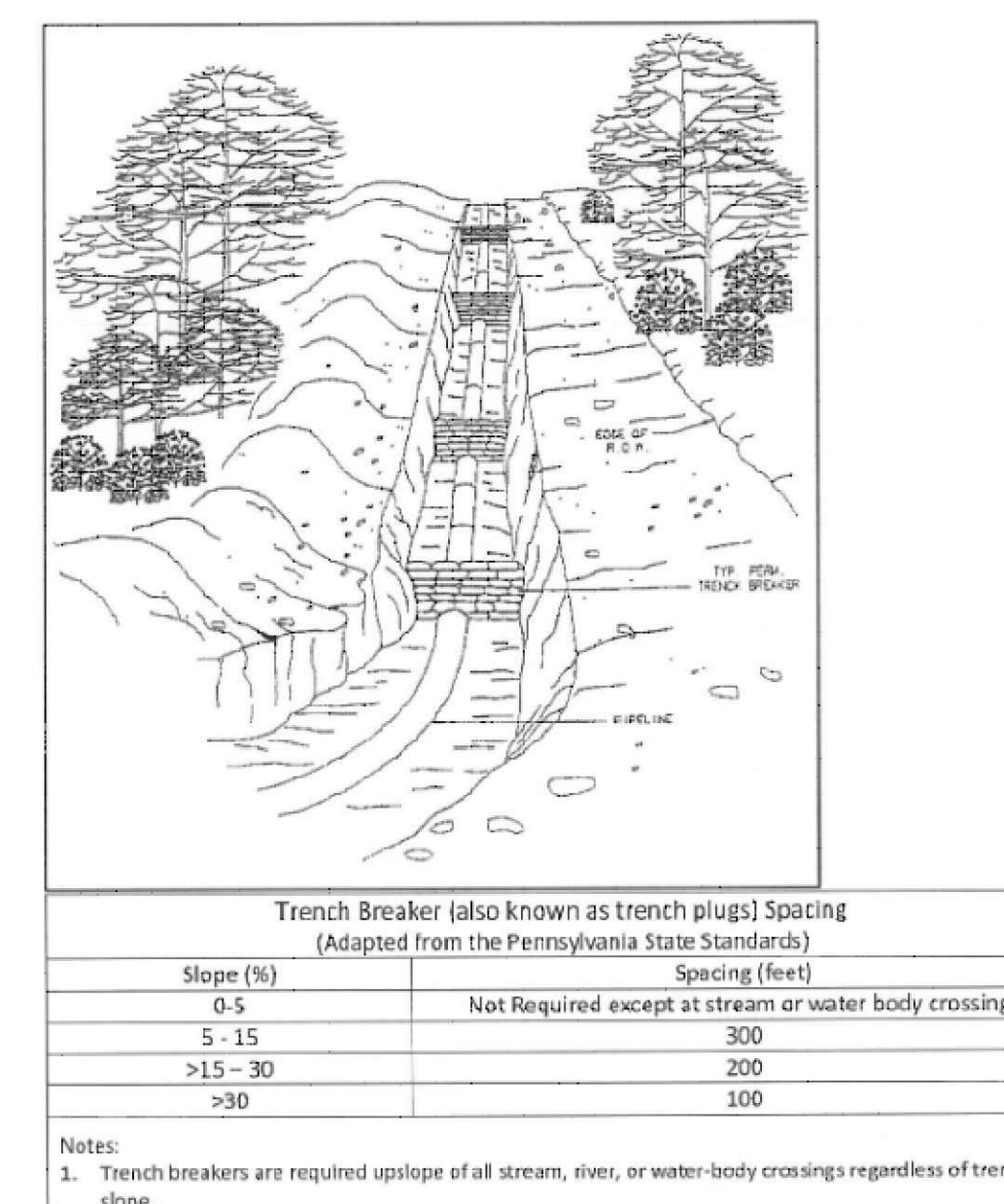

FIGURE 12
 TRENCH BREAKER DETAIL



PREPARED FOR:

Hoffman Falls Wind LLC

90 State Street, Suite 700
 Albany, NY 12207

REVISIONS:

#	DATE	COMMENT	BY	CHK	APR
A	08/25/2023	30% CIVIL DESIGN	HR	DK	AL
B	12/29/2023	60% CIVIL DESIGN	HR	HR	AL

Hoffman Falls
Wind Project
 Madison County, New York

Construction Details -
 14

ISSUE FOR PERMIT

DATE: 12/29/2023
 SHEET: C713
 REV: B

FIGURE 3.6
FLOW DIFFUSER DETAIL

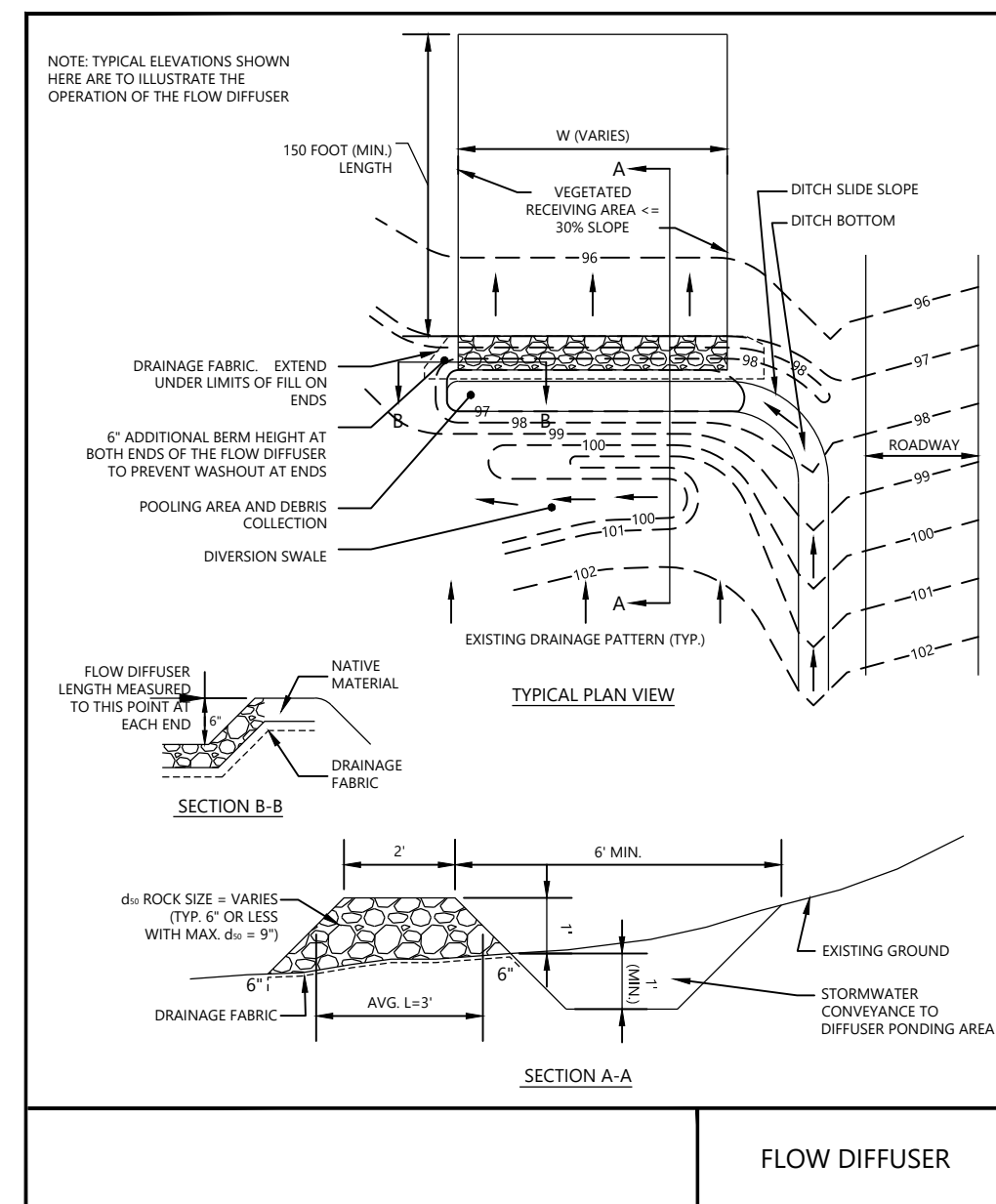

FLOW DIFFUSER

FIGURE 3.18
RIPRAP OUTLET PROTECTION DETAIL (1)

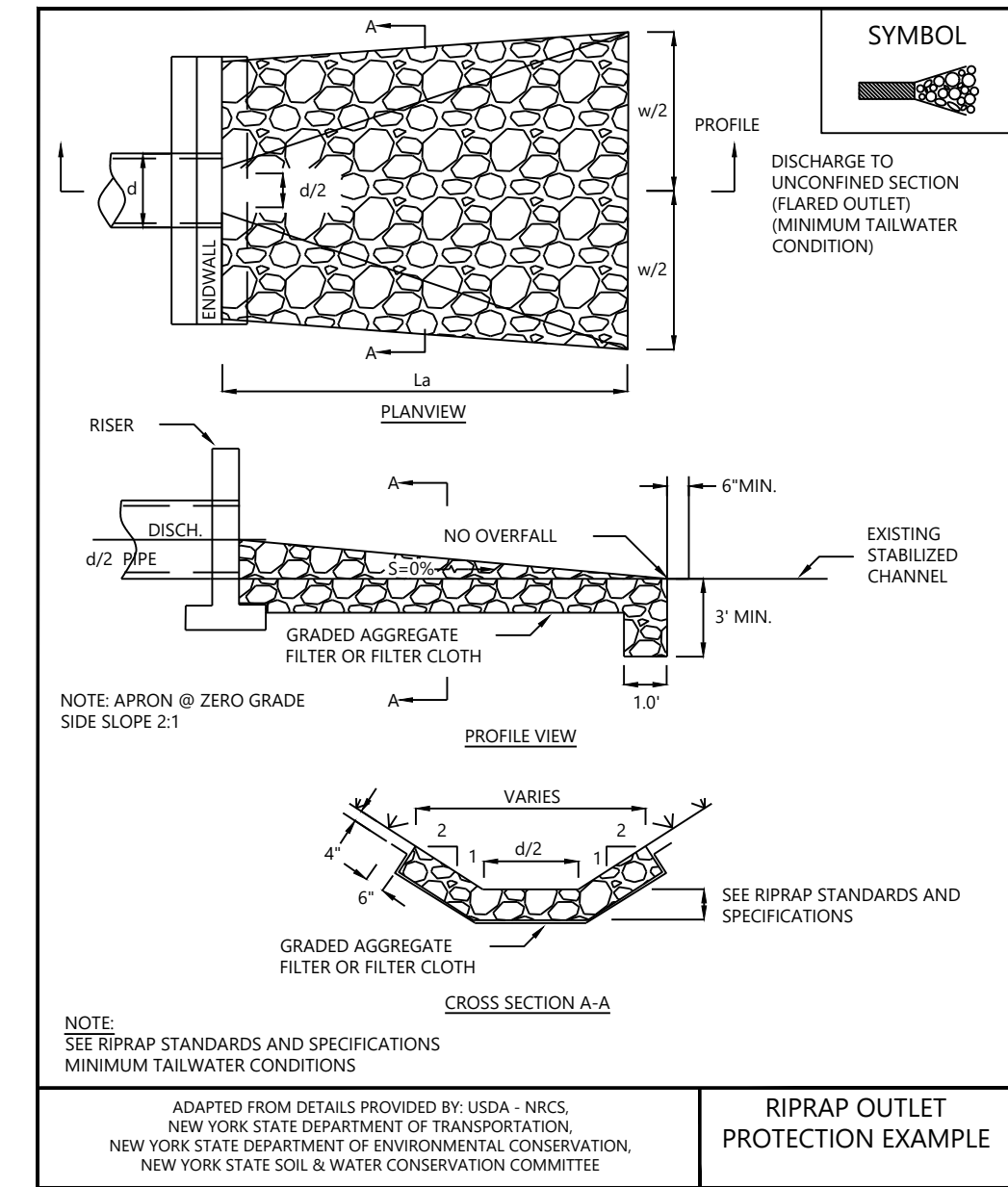

RIPRAP OUTLET PROTECTION EXAMPLE

FIGURE 3.19
RIPRAP OUTLET PROTECTION DETAIL (2)

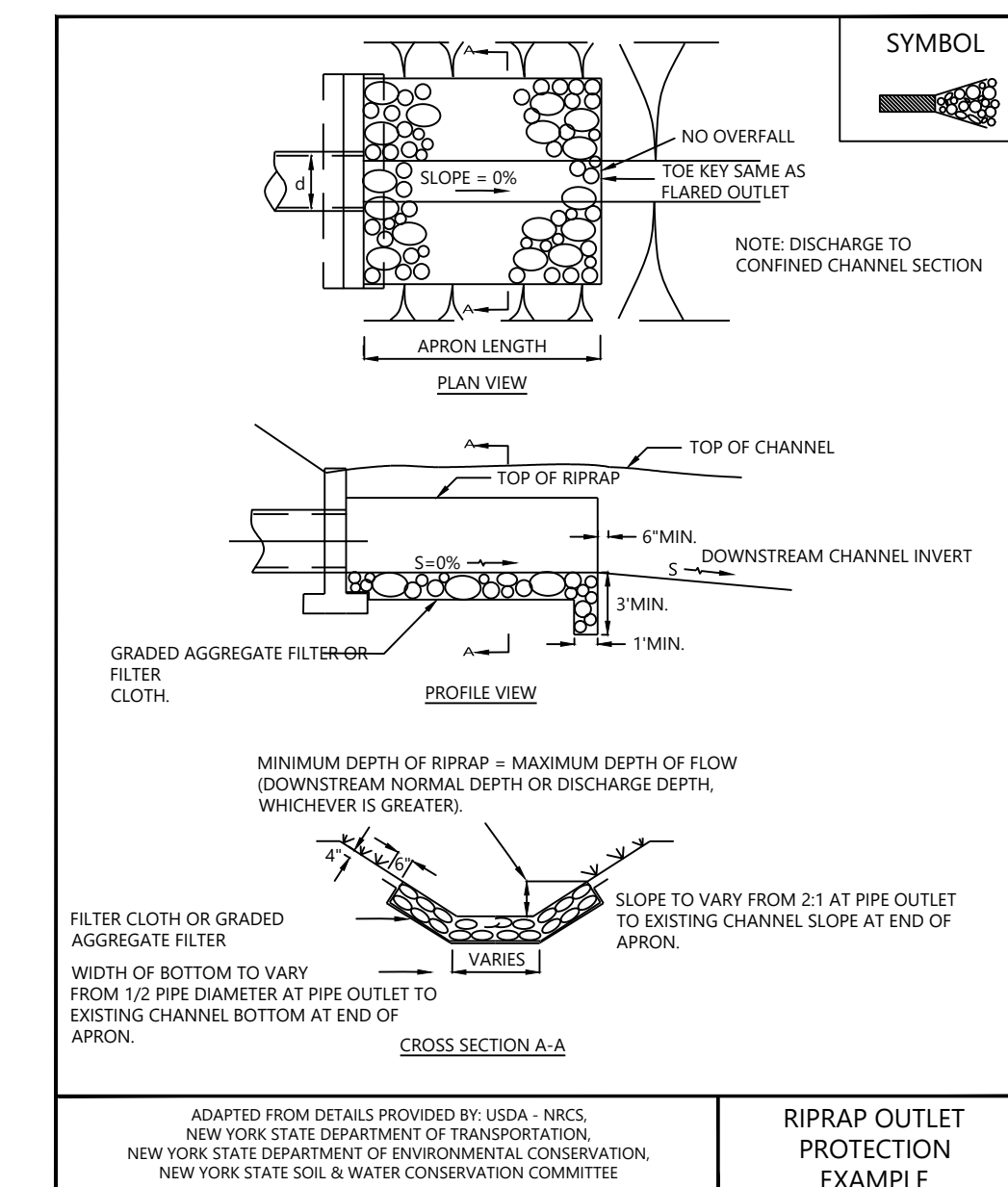

RIPRAP OUTLET PROTECTION EXAMPLE

SCHEDULE FOR STORM DRAIN			
CULVERT DIAMETER (D)	LENGTH (L)	WIDTH (W)	STONE d ₅₀
12"	8'	12'	6"
18"	10'	12'	6"
24"	12'	14'	6"
30"	16'	20'	12"
36"	20'	23'	12"

The minimum thickness of the riprap layer shall be 1.5 times the maximum rock diameter for d₅₀ of 15 inches or less, and 1.2 times the maximum rock size for d₅₀ greater than 15 inches. The following chart lists some examples:

D ₅₀ (inches)	d _{max} (inches)	Minimum Blanket Thickness (inches)
4	6	9
6	9	14
9	14	20
12	18	27
15	22	32
18	27	32
21	32	38
24	36	43

FIGURE 3.20
RIPRAP OUTLET PROTECTION DETAIL (3)

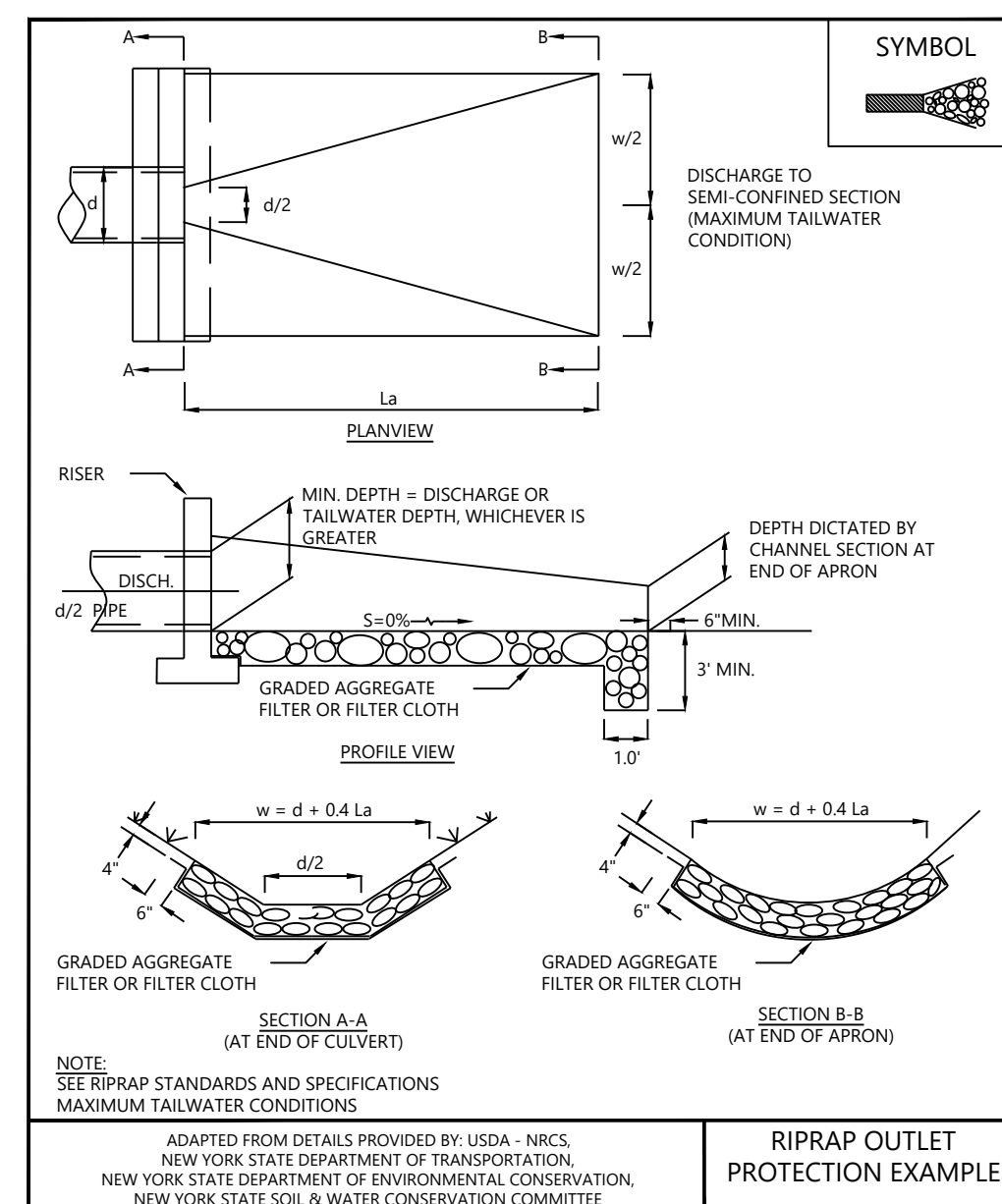

RIPRAP OUTLET PROTECTION EXAMPLE

FIGURE 3.22
WATER BAR DETAIL

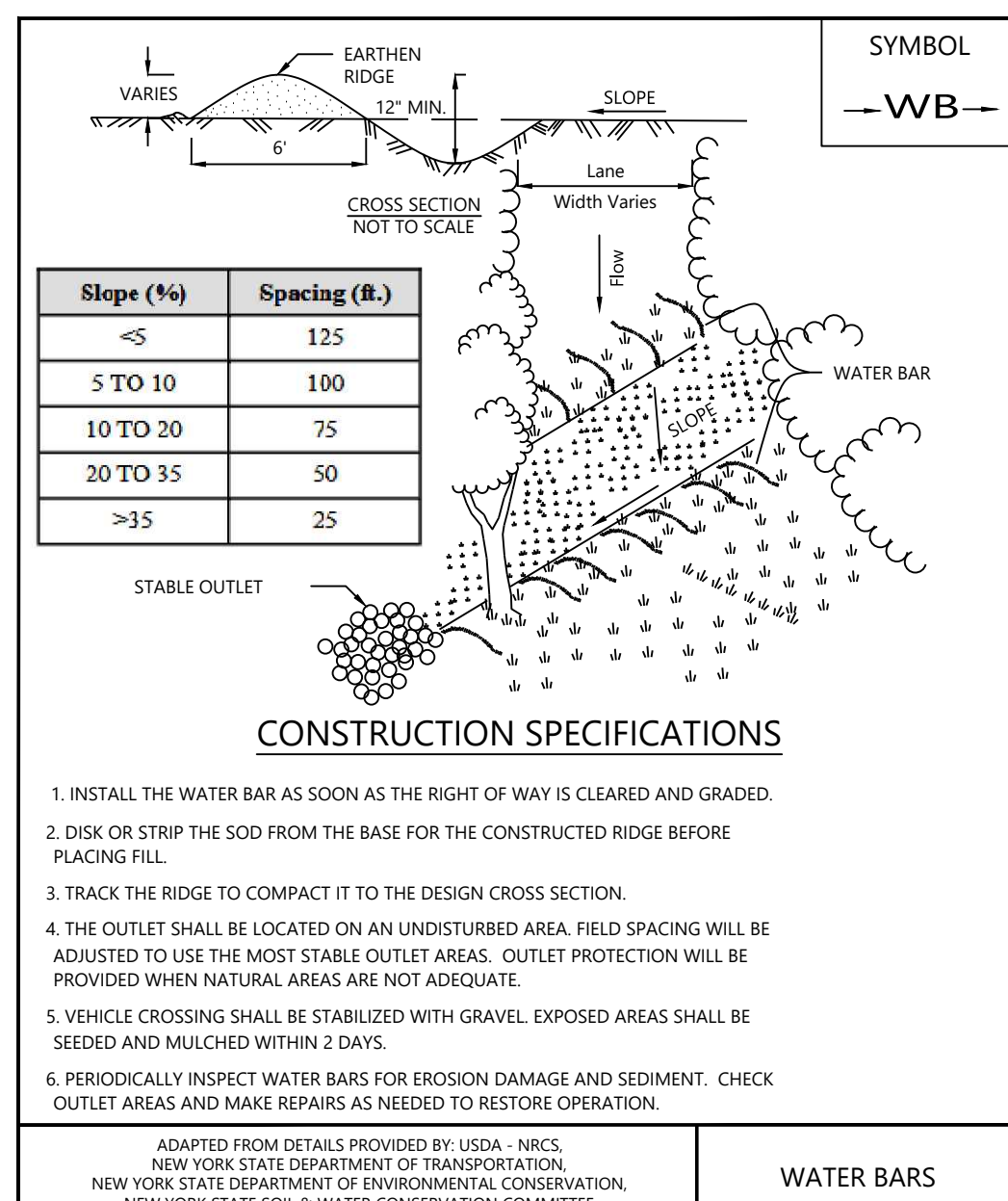

WATER BARS

FIGURE 4.8
FIBER ROLL

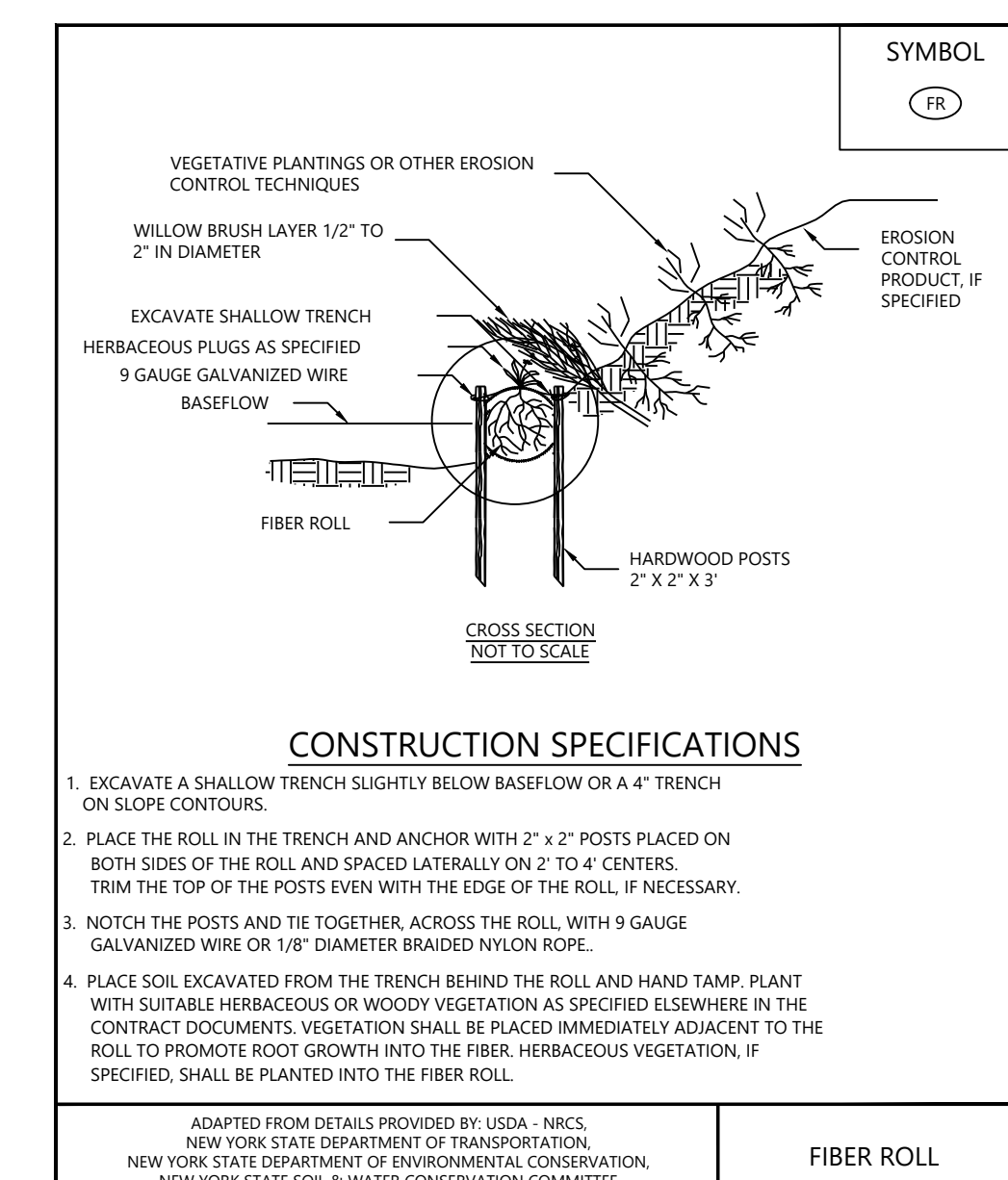

FIBER ROLL

PREPARED FOR:

Hoffman Falls Wind LLC

90 State Street, Suite 700
Albany, NY 12207

REVISIONS:

#	DATE	COMMENT	BY	CHK	APR
A	08/25/2023	30% CIVIL DESIGN	HR	DK	AL
B	12/29/2023	60% CIVIL DESIGN	HR	HR	AL

Hoffman Falls Wind Project
Madison County, New York

Construction Details - 15

ISSUE FOR PERMIT

DATE: 12/29/2023
SHEET: C714
REV: B

Figure 4.1
Angles of Repose of Riprap Stones (FHWA)

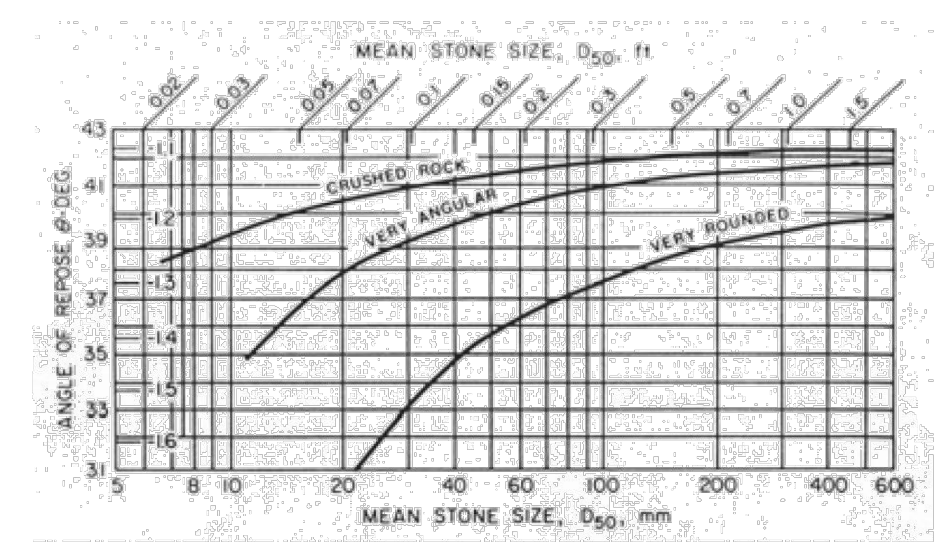
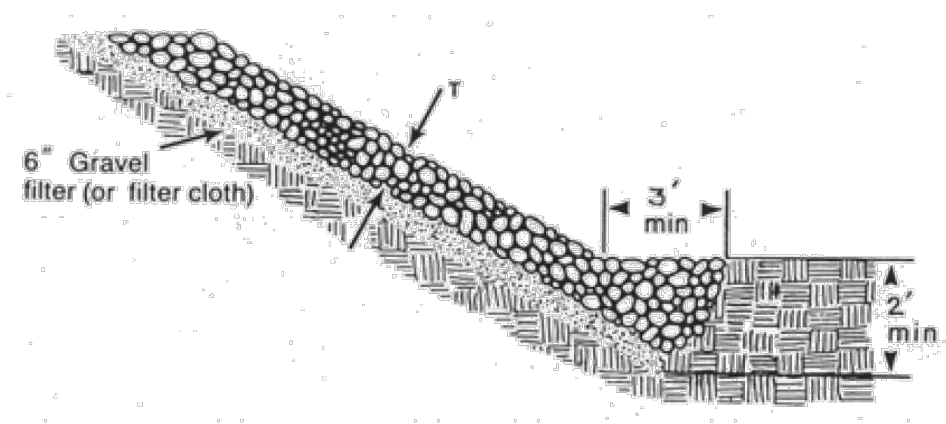

Figure 4.2
Typical Riprap Slope Protection Detail



New York State Standards and Specifications For Erosion and Sediment Control Page 4.9 November 2016

FIGURE 4.3
RIPRAP CHANNEL STABILIZATION

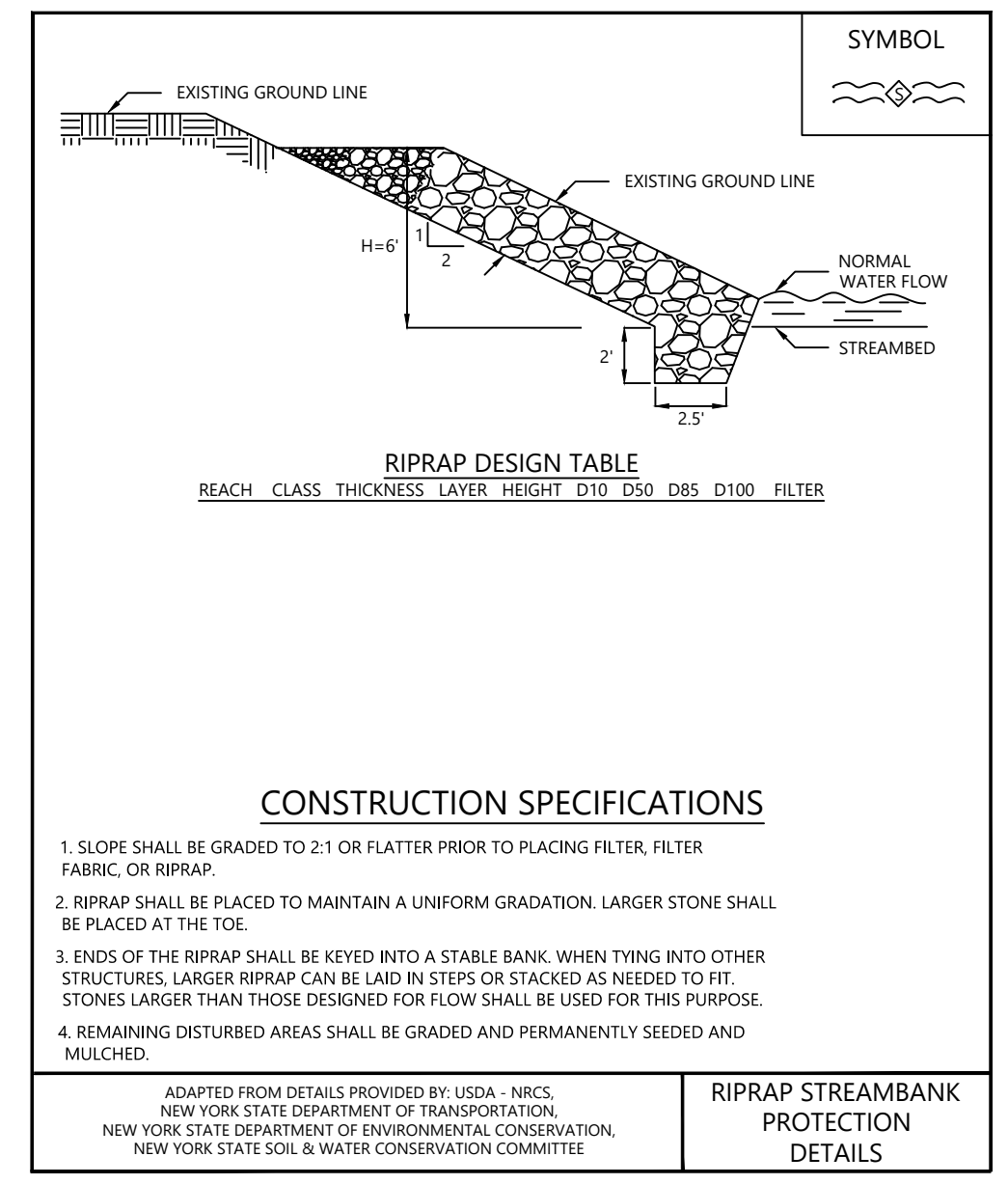
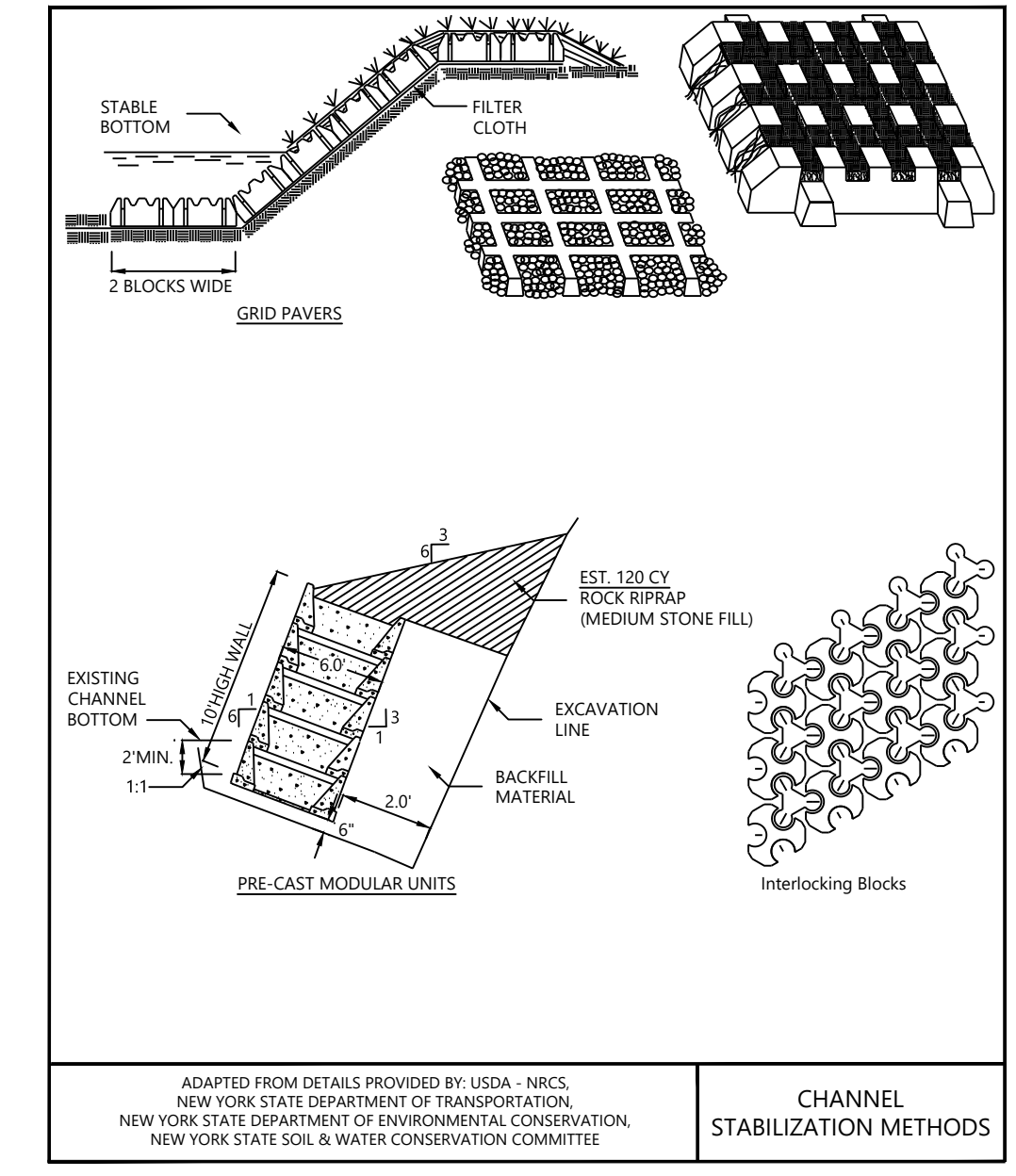

FIGURE 4.4
CHANNEL STABILIZATION METHODS



PREPARED FOR:

Hoffman Falls Wind LLC

90 State Street, Suite 700
Albany, NY 12207

REVISIONS:

#	DATE	COMMENT	BY	CHK	APR
A	08/25/2023	30% CIVIL DESIGN	HR	DK	AL
B	12/29/2023	60% CIVIL DESIGN	HR	HR	AL

FIGURE 4.9
TYPICAL SECTION OF SERRATED CUT SLOPE

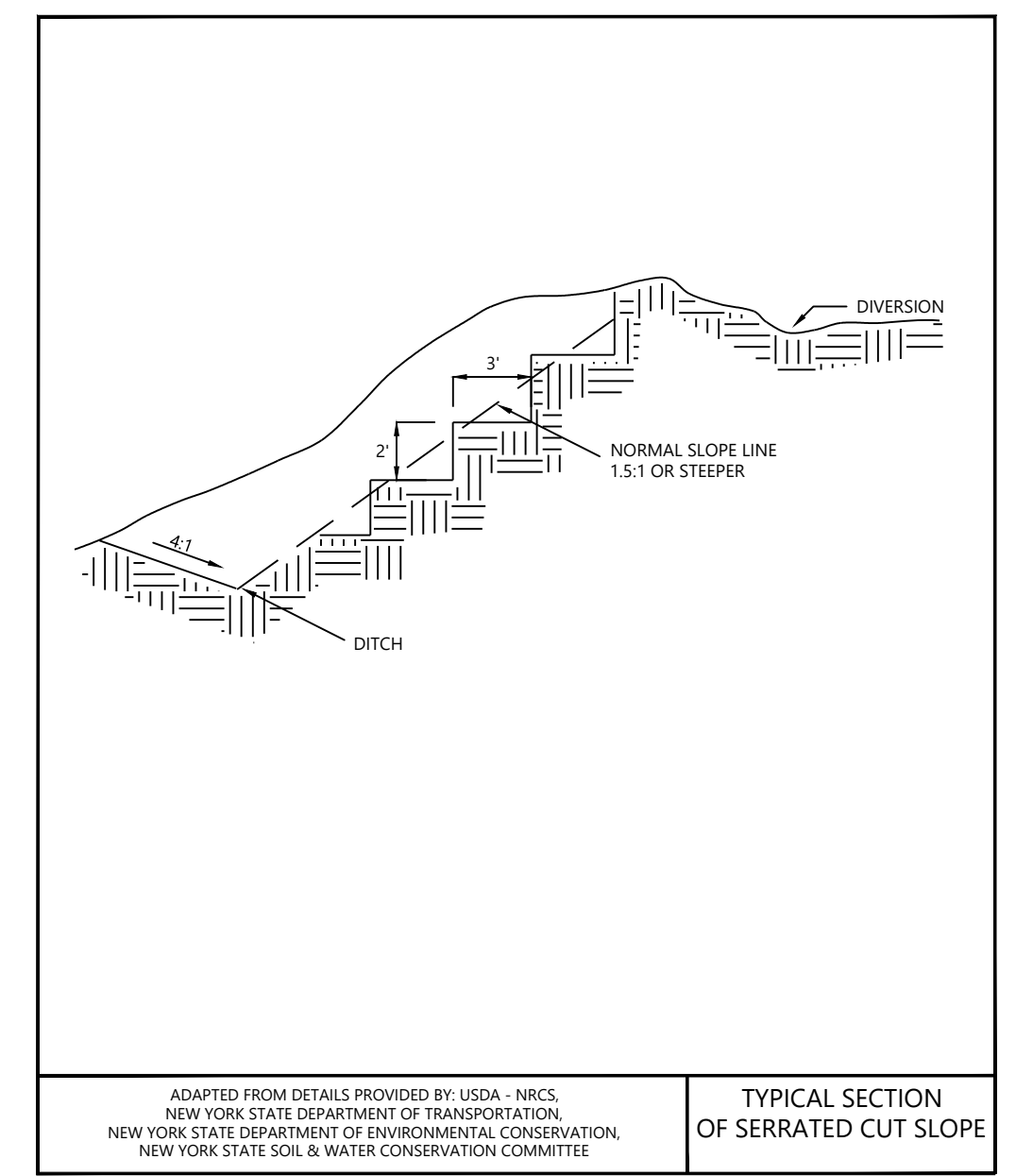

FIGURE 4.10
LANDGRADING

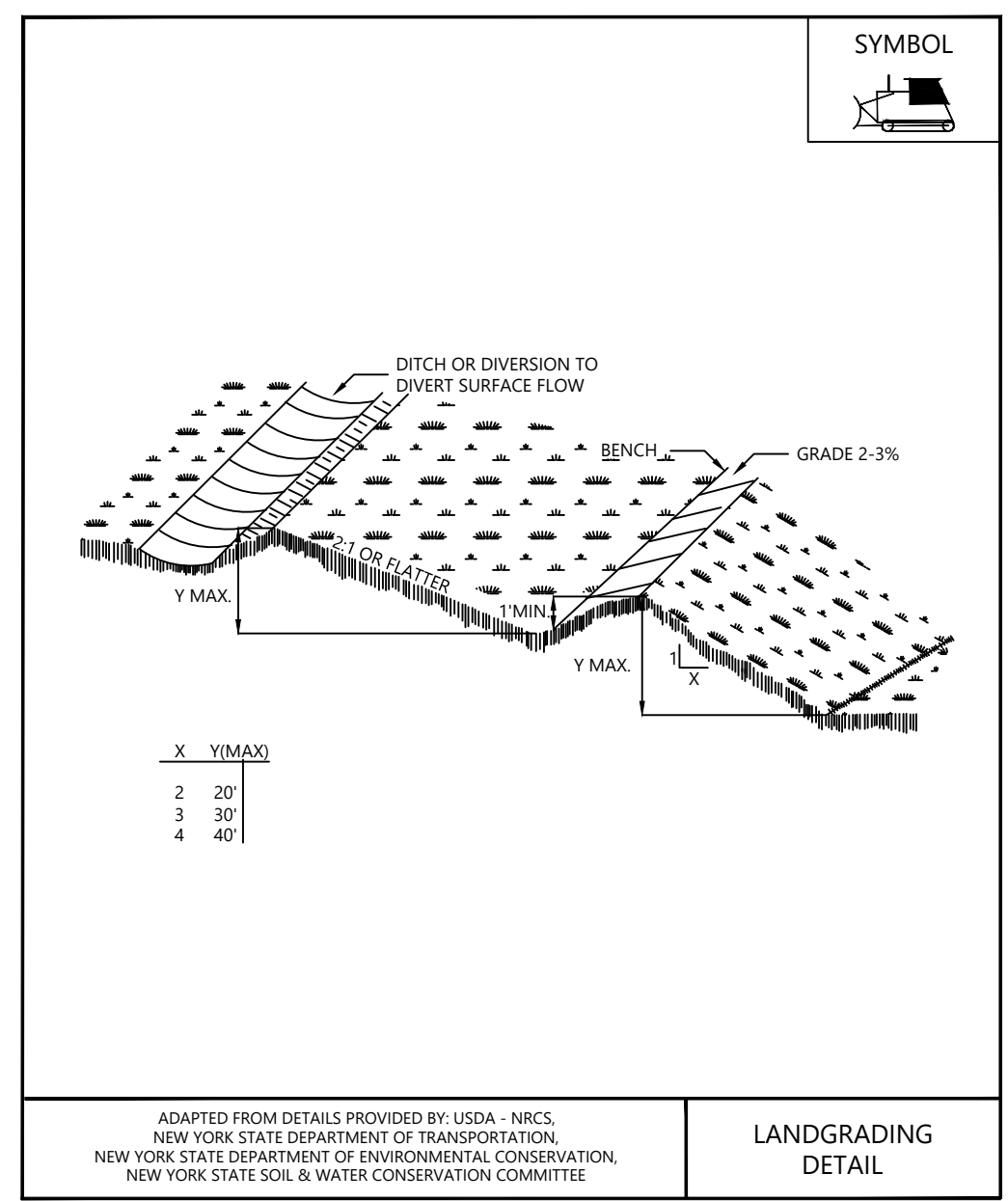

FIGURE 4.11
LANDGRADING - CONSTRUCTION SPECIFICATIONS

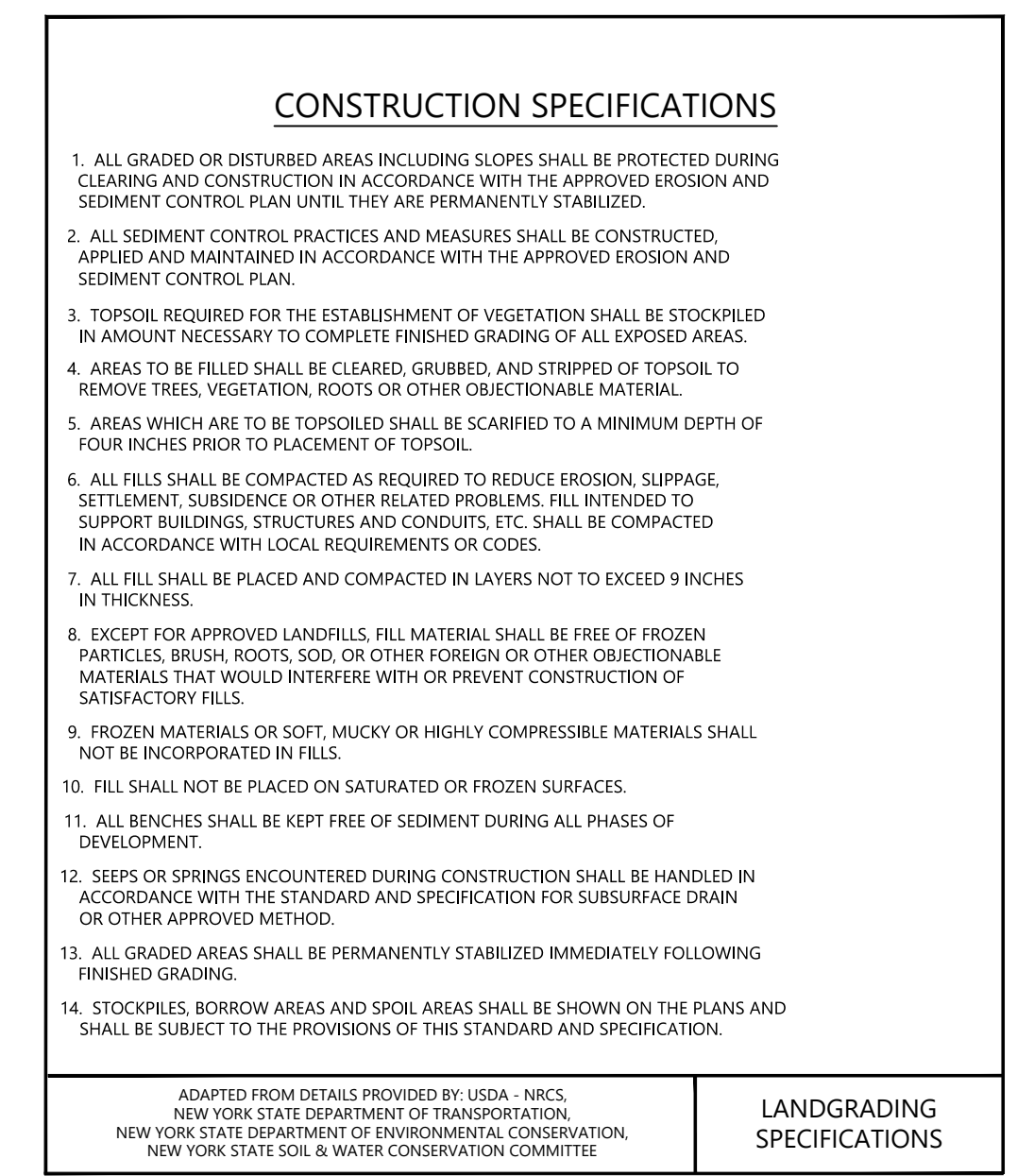
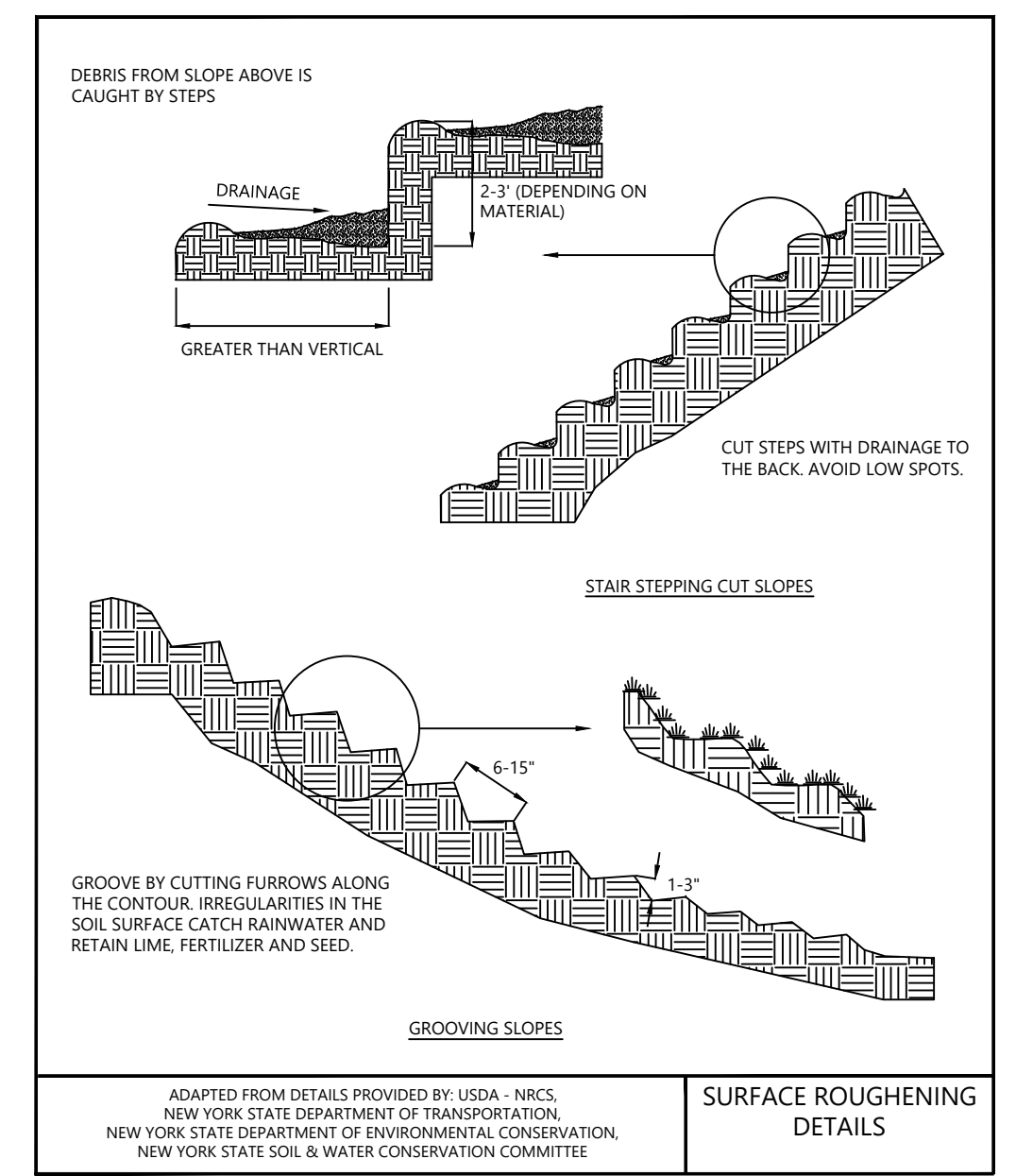

FIGURE 4.18
SURFACE ROUGHENING



Hoffman Falls Wind Project
Madison County, New York

Construction Details - 16

ISSUE FOR PERMIT

DATE: 12/29/2023
SHEET: C715
REV: B

FIGURE 5.7
 ROCK DAM

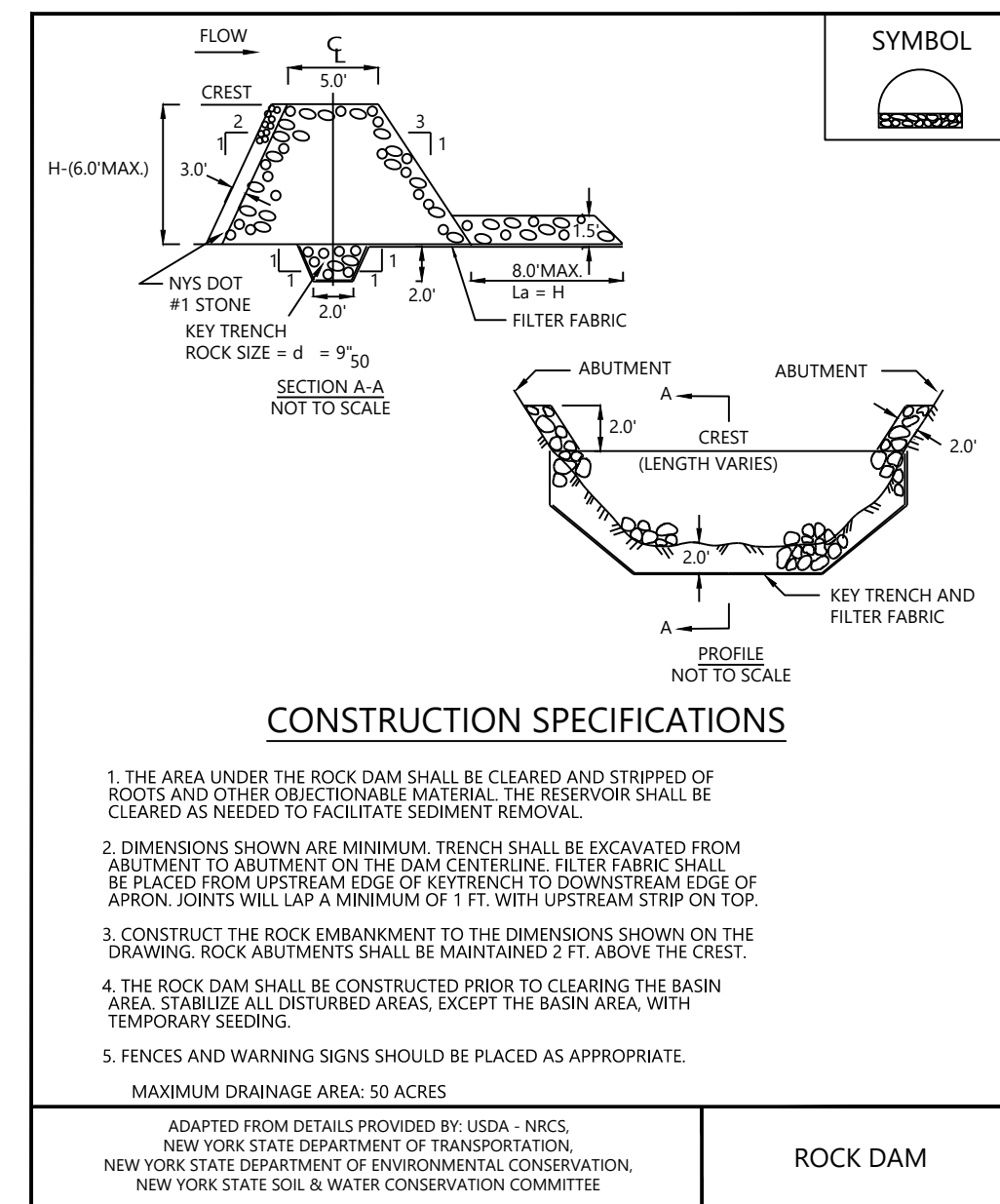
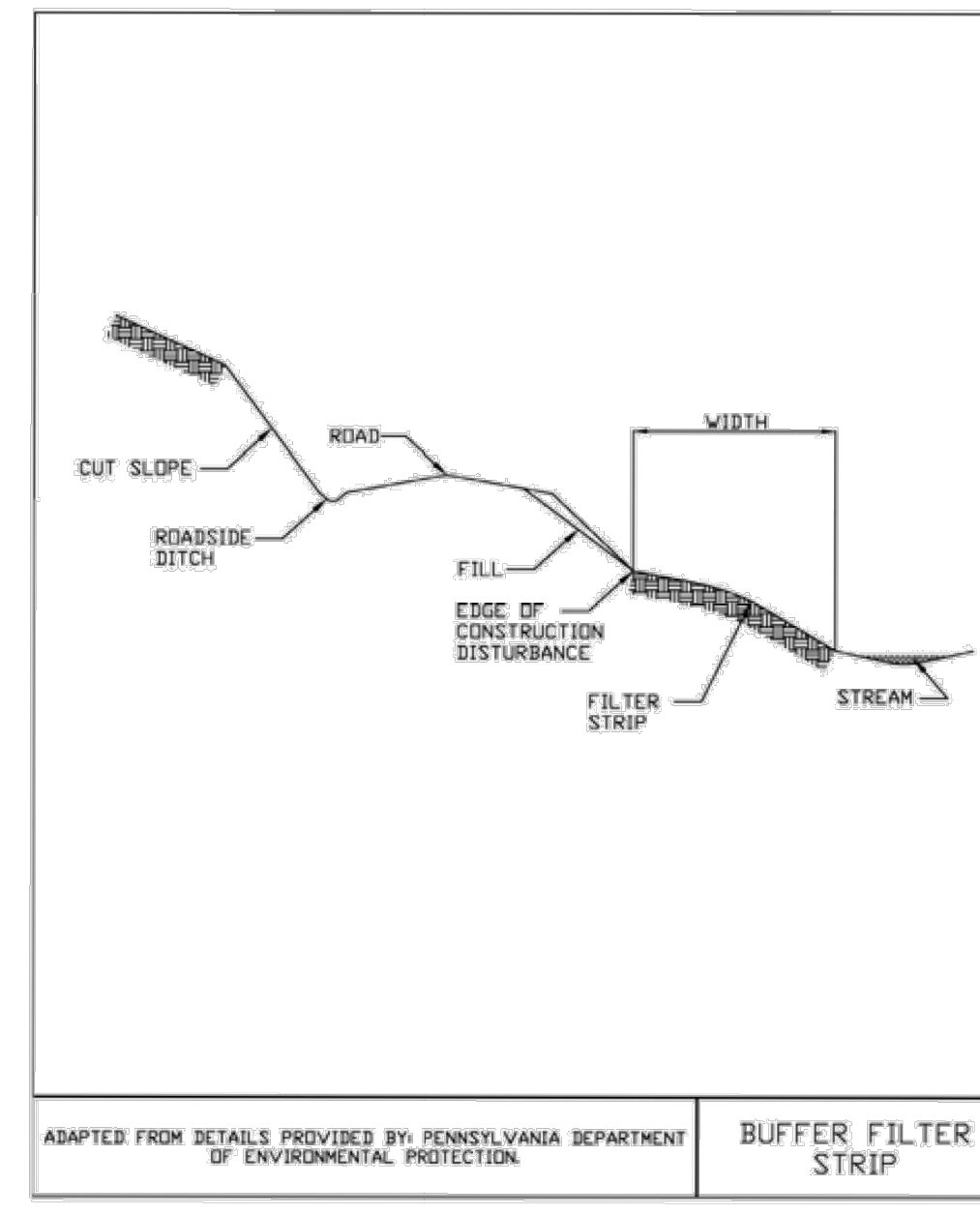

Figure 5.1
 Buffer Filter Strip



November 2016 Page 5.4 New York State Standards and Specifications For Erosion and Sediment Control

PREPARED FOR:

Hoffman Falls Wind LLC

90 State Street, Suite 700
 Albany, NY 12207

REVISIONS:

#	DATE	COMMENT	BY	CHK	APR
A	08/25/2023	30% CIVIL DESIGN	HR	DK	AL
B	12/29/2023	60% CIVIL DESIGN	HR	HR	AL

FIGURE 5.2
 COMPOST FILTER SOCK

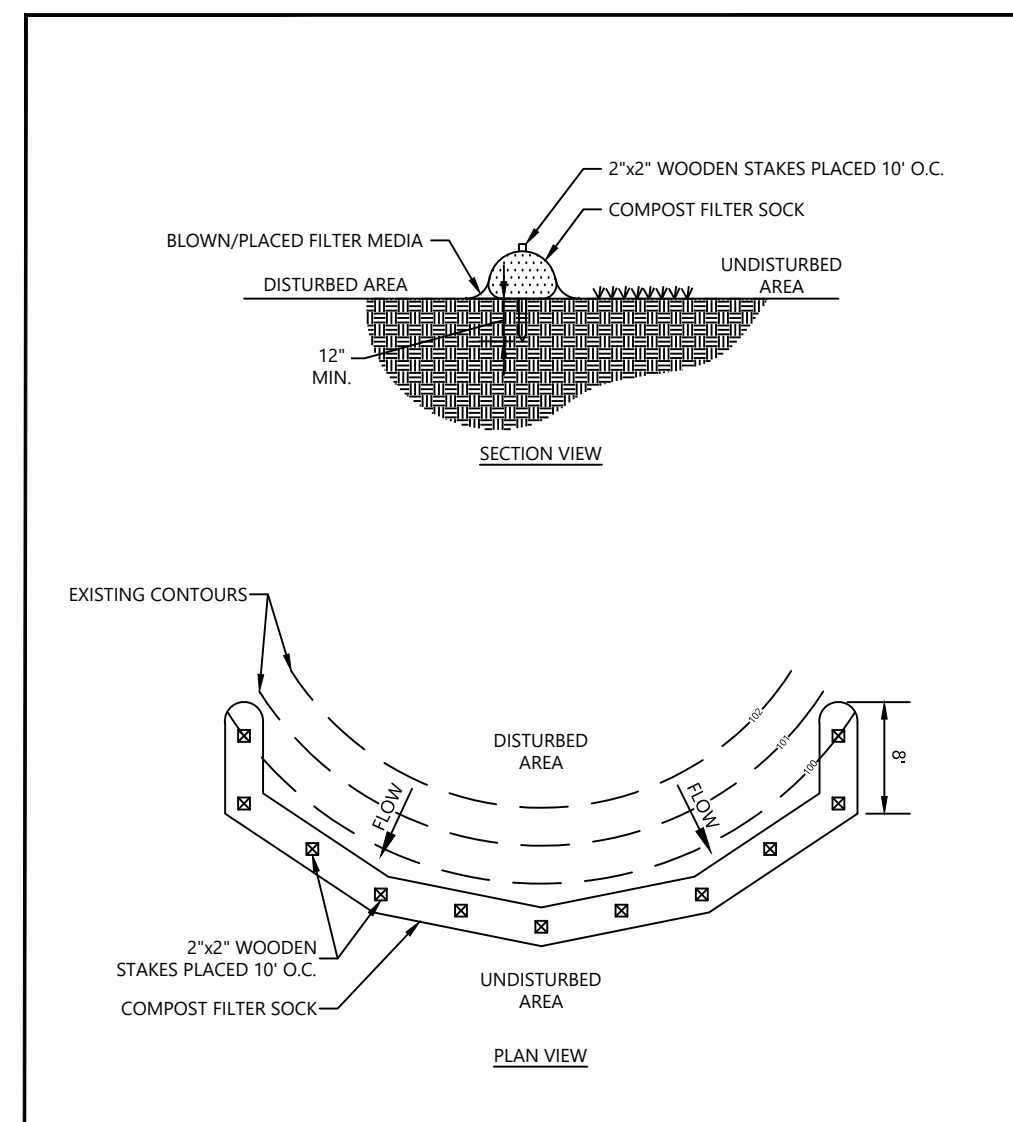

1. SOCK FABRIC SHALL MEET STANDARDS OF TABLE 5.1. COMPOST SHALL MEET THE STANDARDS LISTED ON TABLE 5.2.
2. COMPOST FILTER SOCK SHALL BE PLACED AT EXISTING LEVEL GRADE. BOTH ENDS OF THE SOCK SHALL BE EXTENDED AT LEAST 8 FEET UP SLOPE AT 45 DEGREES TO THE MAIN SOCK ALIGNMENT FIGURE 5.2. MAXIMUM SLOPE LENGTH ABOVE ANY SOCK SHALL NOT EXCEED THAT SHOWN ON FIGURE 5.2. STAKES MAY BE INSTALLED IMMEDIATELY DOWN-SLOPE OF THE SOCK IF SO SPECIFIED BY THE MANUFACTURER.
3. TRAFFIC SHALL NOT BE PERMITTED TO CROSS FILTER SOCKS.
4. ACCUMULATED SEDIMENT SHALL BE REMOVED WHEN IT REACHES HALF THE ABOVEGROUND HEIGHT OF THE SOCK AND DISPOSED IN THE MANNER DESCRIBED ELSEWHERE IN THE PLAN.
5. SOCKS SHALL BE INSPECTED WEEKLY AND AFTER EACH RUNOFF EVENT. DAMAGED SOCKS SHALL BE REPAIRED ACCORDING TO MANUFACTURER'S SPECIFICATIONS OR REPLACED WITHIN 24 HOURS OF INSPECTION.
6. BIODEGRADABLE FILTER SOCKS SHALL BE REPLACED AFTER 6 MONTHS; PHOTODEGRADABLE SOCKS AFTER 1 YEAR. POLYPROPYLENE SOCKS SHALL BE REPLACED ACCORDING TO MANUFACTURER'S RECOMMENDATIONS.
7. UPON STABILIZATION OF THE AREA TRIBUTARY TO THE SOCKS, STAKES SHALL BE REMOVED. THE SOCK MAY BE LEFT IN PLACE AND VEGETATED OR REMOVED. IN THE LATTER CASE, THE MESH SHALL BE CUT OPEN AND THE MULCH SPREAD AS A SOIL SUPPLEMENT.

FIGURE 5.30
 REINFORCED SILT FENCE

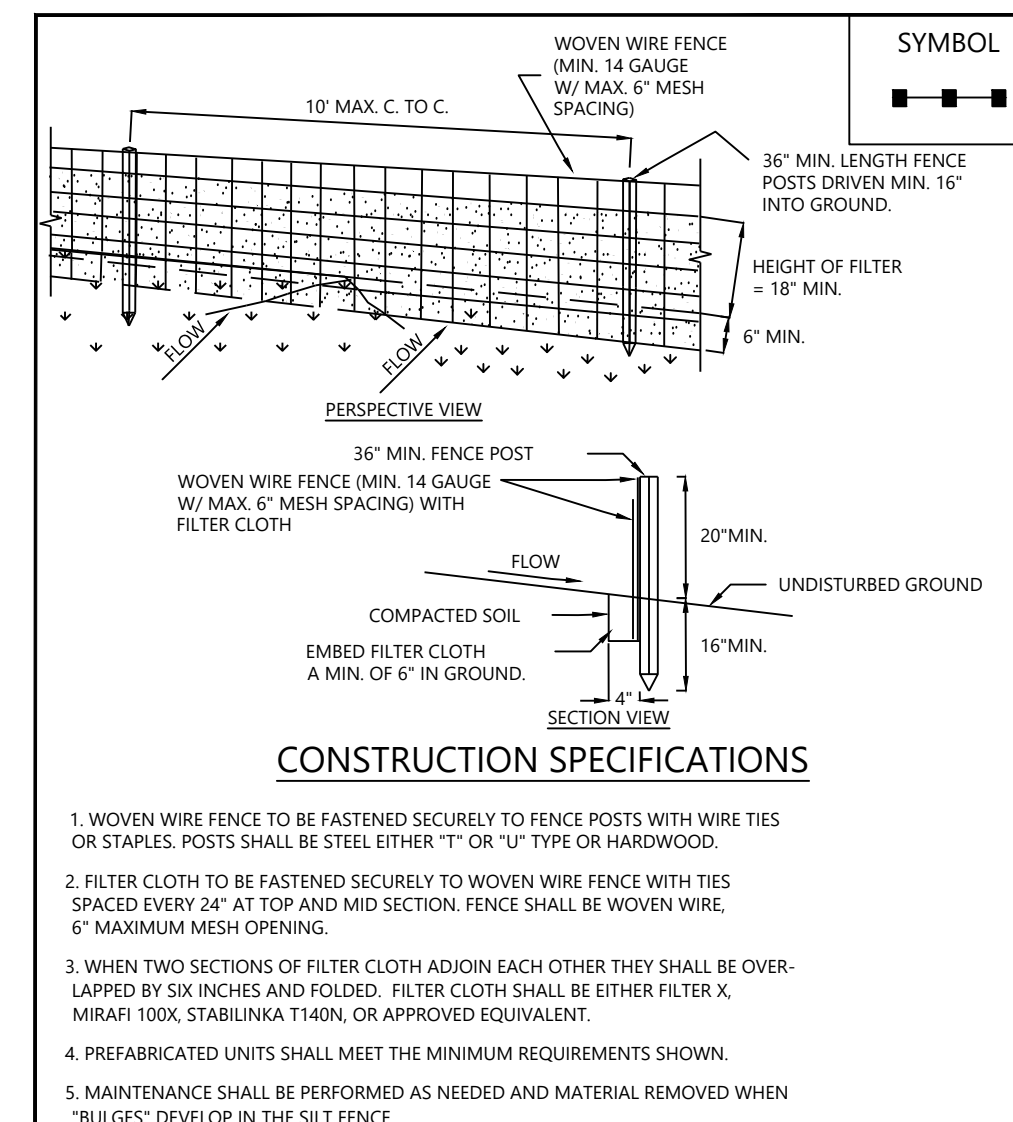

1. WOVEN WIRE FENCE TO BE FASTENED SECURELY TO FENCE POSTS WITH WIRE TIES OR STAPLES. POSTS SHALL BE STEEL EITHER "T" OR "U" TYPE OR HARDWOOD.
2. FILTER CLOTH TO BE FASTENED SECURELY TO WOVEN WIRE FENCE WITH TIES SPACED EVERY 24" AT TOP AND MID SECTION. FENCE SHALL BE WOVEN WIRE, 6" MAXIMUM MESH OPENING.
3. WHEN TWO SECTIONS OF FILTER CLOTH ADJOIN EACH OTHER THEY SHALL BE OVERLAPPED BY SIX INCHES AND FOLDED. FILTER CLOTH SHALL BE EITHER FILTER X, MIRAFI 100X, STABILINKA T140N, OR APPROVED EQUIVALENT.
4. PREFABRICATED UNITS SHALL MEET THE MINIMUM REQUIREMENTS SHOWN.
5. MAINTENANCE SHALL BE PERFORMED AS NEEDED AND MATERIAL REMOVED WHEN "BULGES" DEVELOP IN THE SILT FENCE.

FIGURE 5.34
 STRAW BALE DIKE

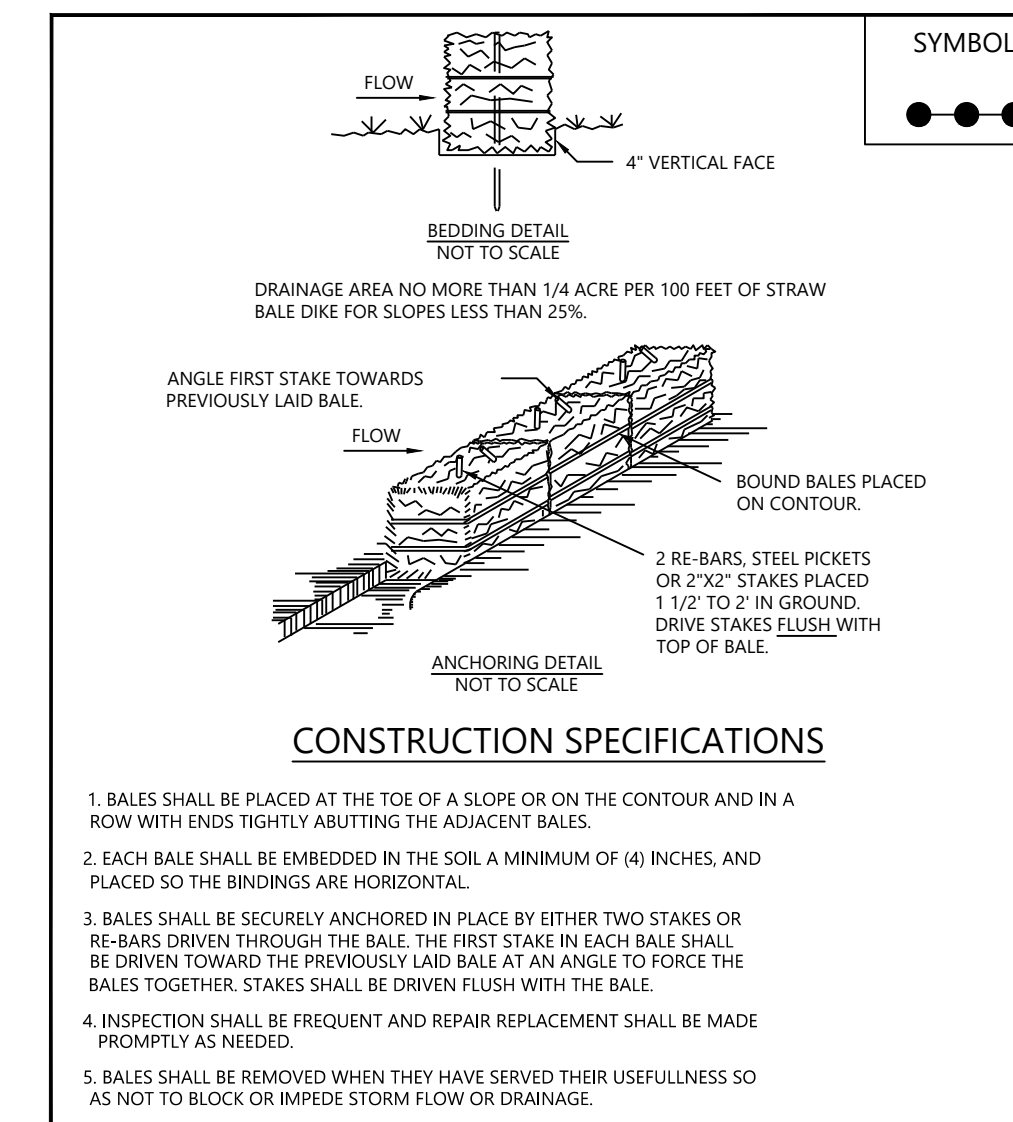

1. BALES SHALL BE PLACED AT THE TOE OF A SLOPE OR ON THE CONTOUR AND IN A ROW WITH ENDS TIGHTLY ABUTTING THE ADJACENT BALES.
2. EACH BALE SHALL BE EMBEDDED IN THE SOIL A MINIMUM OF (4) INCHES, AND PLACED SO THE BINDINGS ARE HORIZONTAL.
3. BALES SHALL BE SECURELY ANCHORED IN PLACE BY EITHER TWO STAKES OR RE-BARS DRIVEN THROUGH THE BALE. THE FIRST STAKE IN EACH BALE SHALL BE DRIVEN TOWARD THE PREVIOUSLY LAID BALE AT AN ANGLE TO FORCE THE BALES TOGETHER. STAKES SHALL BE DRIVEN FLUSH WITH THE TOP OF BALE.
4. INSPECTION SHALL BE FREQUENT AND REPAIR REPLACEMENT SHALL BE MADE PROMPTLY AS NEEDED.
5. BALES SHALL BE REMOVED WHEN THEY HAVE SERVED THEIR USEFULNESS SO AS NOT TO BLOCK OR IMPEDE STORM FLOW OR DRAINAGE.

**Hoffman Falls
 Wind Project**
 Madison County, New York

Construction Details -
 17

ISSUE FOR PERMIT

DATE: 12/29/2023 REV:
 SHEET: C716 B

PREPARED FOR:

Hoffman Falls Wind LLC

90 State Street, Suite 700
Albany, NY 12207

REVISIONS:

#	DATE	COMMENT	BY	CHK	APR
A	08/25/2023	30% CIVIL DESIGN	HR	DK	AL
B	12/29/2023	60% CIVIL DESIGN	HR	HR	AL

TABLE 1: TURBINE TABLE

NEW YORK CENTRAL NSRS11 (2011) SPCS US FEET

Name	Northing	Easting	Latitude	Longitude
T-1	1075511.787	1037006.434	42.5656199	-75.4624824
T-2	1073712.913	1038393.746	42.5638299	-75.4606406
T-3	1071382.778	1040557.6	42.5615077	-75.4537621
T-4	1069873.342	1041154.363	42.560011	-75.4529798
T-5	1079987.3	1044217.008	42.5739705	-75.4447278
T-6	1078346.45	1044405.838	42.5723481	-75.4444959
T-7	1075894.323	1044637.994	42.5659239	-75.4442166
T-8	1077144.608	1045948.627	42.5711458	-75.4424375
T-9	1078872.407	1047363.048	42.5728382	-75.4405122
T-10	1075566.674	1047316.099	42.5655737	-75.4406202
T-11	1070002.36	1049296.138	42.5600581	-75.4340342
T-12	1072095.602	1050573.951	42.5621127	-75.4322878
T-13	1064761.263	1056099.017	42.5508123	-75.4209638
T-14	1071535.532	1056316.83	42.5615008	-75.4205756
T-15	1069949.481	1056866.187	42.5559286	-75.4158596
T-16	1062208.512	1060580.833	42.5442442	-75.4109775
T-17	1066213.119	1062943.895	42.5521744	-75.4037444
T-18	1064748.722	1063523.552	42.5507219	-75.4029866
T-19	1066727.375	1069557.386	42.552611	-75.3908488
T-20	1062811.835	1070184.083	42.5447369	-75.3900649
T-21	1064860.755	1070170.086	42.5507607	-75.3900532
T-22	1063842.787	1073950.768	42.5457136	-75.380988
T-23	1066259.853	1074357.121	42.5520963	-75.3804054
T-24	1071828.276	1060792.382	42.5617432	-75.4105552
MET-1	1069794.332	1055737.429	42.9528583	-75.752008
ADLS-1	1076994.162	1042762.918	42.932742	-75.703831

TABLE 2: DRAINAGE CROSSING

Crossings ID	Storm Event	Culvert Size	Water Crossing Type
DC01	100	Culvert Size to be determined in coordination with the USACE and in accordance with the 19 NYCRR §900-2.6(3)(r)(6)	
DC02	100	1-36"; 2-24"; 3-18"	STANDARD DUTY
DC03	100	Culvert Size to be determined in coordination with the USACE	
DC04	100	Culvert Size to be determined in coordination with the USACE and in accordance with the 19 NYCRR §900-2.6(3)(r)(6)	
DC05	100	Culvert Size to be determined in coordination with the USACE and in accordance with the 19 NYCRR §900-2.6(3)(r)(6)	
DC06	100	Culvert Size to be determined in coordination with the USACE	
DC07	100	Culvert Size to be determined in coordination with the USACE	
*DC08	100	Culvert Size to be determined in coordination with the USACE and in accordance with the 19 NYCRR §900-2.6(3)(r)(6)	
DC09	100	Culvert Size to be determined in coordination with the USACE and in accordance with the 19 NYCRR §900-2.6(3)(r)(6)	
DC10	100	1-48"; 2-36"; 3-30"	STANDARD DUTY
DC11	100	1-42"; 2-36"; 3-30"	STANDARD DUTY
DC12	100	Culvert Size to be determined in coordination with the USACE	
DC13	100	Culvert Size to be determined in coordination with the USACE	
DC14	100	Culvert Size to be determined in coordination with the USACE and in accordance with the 19 NYCRR §900-2.6(3)(r)(6)	
DC15	100	1-30"; 2-24"; 3-18"	HEAVY DUTY
DC16	100	Culvert Size to be determined in coordination with the USACE	
DC17	100	1-18"	STANDARD DUTY
**DC18	100	-	STANDARD DUTY
**DC19	100	1-24"; 2-18"	STANDARD DUTY
**DC20	100	1-30"; 2-24"; 3-18"	STANDARD DUTY
**DC21	100	1-36"; 2-30"; 3-24"	STANDARD DUTY
DC22	100	1-18"	STANDARD DUTY
DC23	100	1-54"; 2-42"	STANDARD DUTY
DC24	100	1-36"; 2-24"	HEAVY DUTY
**DC25	100	-	STANDARD DUTY
DC26	50	1-48"; 2-36"; 3-30"	STANDARD DUTY
DC27	100	Culvert Size to be determined in coordination with the USACE and in accordance with the 19 NYCRR §900-2.6(3)(r)(6)	
DC28	100	Culvert Size to be determined in coordination with the USACE and in accordance with the 19 NYCRR §900-2.6(3)(r)(6)	

*INDICATES A STREAM CROSSING THAT WILL NEED BOTH A CULVERT AND HIGH WATER CROSSING
**INDICATES A LOW WATER CROSSING MAY BE MORE FEASIBLE

TABLE 3: ENTRANCE CROSSING

Entrance ID	Storm Event	Culvert Size
EC01	100	1-18"
EC02	100	1-30"; 2-24"; 3-18"
EC04	100	1-36"; 2-24"
EC06	100	1-18"
EC07	100	1-24"; 2-18"
EC12	100	1-18"
EC15	100	1-18"
EC16	100	1-18"
EC17	100	1-18"
EC18	100	Culvert Size to be determined in coordination with the USACE

TABLE 4: STORMWATER BASIN TABLE

BASIN ID	PLAN SHEET	DRAINAGE AREA (AC)	REQUIRED VOLUME (AC-FT)	PROVIDED VOLUME (AC-FT)	BERM WIDTH (FT)	TOP OF BERM ELEVATION (FT)	BASIN BOTTOM ELEVATION (FT)	EOF ELEVATION (FT)	EOF WIDTH (FT)	EOF DEPTH (FT)	OUTLET CULVERT SIZE (IN)	OUTLET CULVERT ELEVATION (FT)	SKIMMER SIZE (IN)	RISER SIZE (IN)	RISER ELEVATION (FT)
1	EC301	TBD	0.52	0.52	5	1665.00	1662.00	1664.40	5	2.2	12"	1661.50	NA	NA	NA
2	EC310	TBD	0.10	0.16	5	1623.70	1621.70	1623.20	5	1.5	12"	1621.00	NA	NA	NA

Hoffman Falls Wind Project

Madison County, New York

Construction Tables

ISSUE FOR PERMIT

DATE: 12/29/2023 REV:

SHEET: C717 B

COMPLIANCE GENERAL NOTES

1. THE CONTRACTOR SHALL CONSTRUCT THE FACILITY CONSISTENT WITH THE NEW YORK STATE DEPARTMENT OF AGRICULTURE AND MARKETS (DAM) GUIDELINES FOR AGRICULTURAL MITIGATION FOR WIND POWER PROJECTS, TO THE MAXIMUM EXTENT PRACTICABLE.
2. IMPACTS TO ARCHEOLOGICAL AND HISTORIC RESOURCES SHALL BE AVOIDED OR MINIMIZED TO THE EXTENT PRACTICABLE. CONSTRUCTION, INCLUDING SITE CLEARING OR OTHER DISTURBANCE, SHALL NOT BE ALLOWED IN ANY AREAS THAT HAVE NOT BEEN REVIEWED AND APPROVED FOR THE PRESENCE OF CULTURAL RESOURCES.
3. THE MAPPED LOCATIONS OF IDENTIFIED ARCHAEOLOGICAL SITES, SURROUNDED BY AN AVOIDANCE BUFFER, ARE IDENTIFIED AS "ENVIRONMENTAL SENSITIVE AREAS" ON THE CONSTRUCTION DRAWINGS AND ARE TO BE MARKED IN THE FIELD BY CONSTRUCTION FENCING WITH SIGNS THAT RESTRICT ACCESS.
4. CONTRACTOR MUST COMPLY WITH THE PROJECT UNANTICIPATED DISCOVERY PLAN, WHICH ESTABLISHES PROCEDURES IN THE EVENT THAT RESOURCES OF CULTURAL, HISTORICAL, OR ARCHAEOLOGICAL IMPORTANCE ARE ENCOUNTERED DURING FACILITY CONSTRUCTION.
5. EXCEPT WHERE CROSSED BY PERMITTED ACCESS ROADS OR THROUGH USE OF TEMPORARY MATTING, STREAMS ARE DESIGNATED "NO EQUIPMENT ACCESS" ON THE FINAL FACILITY CONSTRUCTION DRAWINGS AND ROW CLEARING PLANS, AND MUST BE MARKED IN THE FIELD. THE USE OF MOTORIZED EQUIPMENT IS PROHIBITED IN THESE AREAS.
6. A BUFFER ZONE OF 300 FEET IS REFERRED TO AS "RESTRICTED ACTIVITIES AREA" ON THE CONSTRUCTION DRAWINGS AND ROW CLEARING PLANS WHERE FACILITY CONSTRUCTION TRAVERSES STREAMS, WETLANDS AND OTHER BODIES OF WATER. RESTRICTED ACTIVITIES AREAS SHALL BE MARKED IN THE FIELD. RESTRICTIONS WILL INCLUDE NO DEPOSITION OF SLASH WITHIN OR ADJACENT TO A WATER BODY; NO ACCUMULATION OF CONSTRUCTION DEBRIS WITHIN THE AREA; HERBICIDE RESTRICTIONS WITHIN 100 FEET OF A STREAM OR WETLAND (OR AS REQUIRED PER MANUFACTURER'S INSTRUCTIONS); NO DEGRADATION OF STREAM BANKS; NO EQUIPMENT WASHING OR REFUELING WITHIN THE AREA; NO STORAGE OF ANY PETROLEUM OR CHEMICAL MATERIAL; AND NO DISPOSAL OF EXCESS CONCRETE OR CONCRETE WASH WATER. NO REFILLING OR CHEMICAL STORAGE WITHIN 300 FEET.
7. TREE AND VEGETATION CLEARING SHALL BE LIMITED TO THE MINIMUM NECESSARY FOR FACILITY CONSTRUCTION. SURROUNDING TREES AND VEGETATION WILL NOT BE CUT DOWN ON ANY PROPERTY SOLELY TO REDUCE TURBULENCE OR INCREASE WIND FLOW TO THE FACILITY. TO REDUCE MORTALITY TO NESTING/ROOSTING BIRDS AND BATS, ALL TREE CLEARING ACTIVITIES (EXCEPT FOR HAZARD TREE REMOVAL) SHALL BE CONDUCTED BETWEEN NOVEMBER 1 AND APRIL 1 AND DOES NOT INCLUDE TREES LESS THAN OR EQUAL TO 3 INCHES IN DIAMETER AT BREAST HEIGHT (DBH).
8. ALL EQUIPMENT ACCESS, STORAGE OF EQUIPMENT AND MATERIALS, AND OTHER CONSTRUCTION ACTIVITIES WILL BE CONFINED TO THE LIMITS OF DISTURBANCE AS DEPICTED ON THE FINAL CONSTRUCTION DRAWINGS.
9. FUGITIVE DUST RESULTING FROM CONSTRUCTION ACTIVITIES WILL BE MINIMIZED TO THE MAXIMUM EXTENT PRACTICAL BY IMPLEMENTING APPROPRIATE CONTROL MEASURES. THESE MEASURES INCLUDE THE APPLICATION OF MULCH, WATER, OR STONE ON EXPOSED SOILS OR UNPAVED PUBLIC ROADS WHEN DRY AND WINDY CONDITIONS EXIST. A WATERING VEHICLE WILL BE AVAILABLE ON AN AS-NEEDED BASIS. REFER TO DUST CONTROL PLAN BY WESTWOOD.
10. TEMPORARY EROSION CONTROL DEVICES AND STABILIZATION PRACTICES WILL BE INSTALLED SOON AS PRACTICABLE AND APPROPRIATE, IN ACCORDANCE WITH THE SWPPP. EROSION CONTROL DEVICES WILL BE INSTALLED AFTER CLEARING, BUT PRIOR TO SOIL DISTURBANCE OR VEHICULAR TRAFFIC.
11. WOOD CHIP DEPTH SHALL NOT BE GREATER THAN THREE (3) INCHES. WOOD CHIPS SHALL NOT BE STORED OR DISPOSED OF IN WETLANDS, WITHIN STREAM BANKS, DELINEATED FLOODWAYS, OR ACTIVE AGRICULTURAL FIELDS.
12. AREAS DENOTED AS "PROPOSED BLADE SWING AREA" NEED TO BE FREE OF OBJECTS, WHICH INCLUDES BUT IS NOT LIMITED TO TREES AND SIGNS. ADDITIONAL AGGREGATE OR GRUBBING IS NOT NEEDED IN THESE AREAS

THREATENED AND ENDANGERED SPECIES

1. EXCLUDING BALD EAGLES (HALIAEETUS LEUCOCEPHALUS), IF AT ANY TIME AN ACTIVE NEST OF ANY FEDERALLY, OR STATE, LISTED THREATENED OR ENDANGERED (TE) BIRD SPECIES IS DISCOVERED WITHIN AN ACTIVE CLEARING SITE, THE REGIONAL NEW YORK STATE DEPARTMENT OF ENVIRONMENTAL CONSERVATION (DEC) NATURAL RESOURCE SUPERVISOR (607-622-8273) WILL BE NOTIFIED WITHIN FORTY-EIGHT (48) HOURS OF DISCOVERY, AND THE NEST SITE WILL BE MARKED. AN AREA FIVE HUNDRED (500) FEET IN RADIUS AROUND THE NEST WILL BE AVOIDED UNTIL NOTICE TO CONTINUE CONSTRUCTION AT THAT SITE IS GRANTED BY THE REGIONAL DEC NATURAL RESOURCE SUPERVISOR.
2. IF AT ANY TIME A BALD EAGLE NEST OR COMMUNAL ROOST (DEFINED AS A CLOSE CLUSTER OF TREES WITH 4 OR MORE EAGLES OBSERVED PERCHED) IS LOCATED, THE REGIONAL DEC NATURAL RESOURCE SUPERVISOR WILL BE NOTIFIED WITHIN FORTY-EIGHT (48) HOURS OF DISCOVERY, AND PRIOR TO ANY DISTURBANCE OF THE NEST OR IMMEDIATE AREA. AN AREA OF AT LEAST 0.25 MILES (1,320 FEET) IF THERE IS NOT VISUAL BUFFER OR IF THERE IS A VISUAL BUFFER AN AREA OF AT LEAST SIX HUNDRED SIXTY (660) FEET IN RADIUS FROM THE NEST TREE OR COMMUNAL ROOST WILL BE POSTED AND AVOIDED UNTIL NOTICE TO CONTINUE CONSTRUCTION WITHIN THE BUFFER IS GRANTED BY THE REGIONAL DEC NATURAL RESOURCE SUPERVISOR. THE NEST TREE OR COMMUNAL ROOST WILL NOT BE APPROACHED UNDER ANY CIRCUMSTANCES UNLESS AUTHORIZED BY THE REGIONAL DEC NATURAL RESOURCE SUPERVISOR.
3. REPORT ALL OCCURRENCES OF TE AVIAN SPECIES TO THE ENVIRONMENTAL MONITOR. IF A TE AVIAN SPECIES IS OBSERVED DEMONSTRATING BREEDING BEHAVIOR IT SHOULD BE REPORTED TO THE NATURAL RESOURCES SUPERVISOR WITHIN TWENTY-FOUR (24) HOURS.
4. IF ANY DEAD, INJURED OR DAMAGED STATE-LISTED TE SPECIES, OR THEIR PARTS, EGGS, OR NESTS ARE DISCOVERED WITHIN THE PROJECT AREA THE REGIONAL DEC REGION 8 NATURAL RESOURCE SUPERVISOR AND UNITED STATES FISH AND WILDLIFE SERVICE (USFWS) (607-753-9334) MUST BE NOTIFIED WITHIN TWENTY-FOUR (24) HOURS TO ARRANGE FOR RECOVERY AND TRANSFER OF THE SPECIMENS).
5. ALL SNAG AND CAVITY TREES DEFINED UNDER NYSDEC PROGRAM POLICY ONRDLF-2 RETENTION ON STATE FORESTS WILL BE RETAINED UNLESS THEIR REMOVAL IS NECESSARY FOR PROTECTION OF HUMAN LIFE AND PROPERTY. SNAG OR CAVITY TREES MAY BE REMOVED AFTER BEING CLEARED BY THE ENVIRONMENTAL MONITOR WHO SHALL CONDUCT AN EMERGENCE COUNT FOR BATS. UNOCCUPIED SNAGS AND CAVITY TREES WILL BE REMOVED WITHIN TWENTY-FOUR (24) HOURS OF A NEGATIVE EMERGENCE COUNTY.
6. EVALUATE ALL KNOWN AND DOCUMENTED MATERNITY ROOST TREES OF LISTED BAT SPECIES AND ANY TREES WITHIN A 150-FOOT RADIUS OF DOCUMENTED SUMMER OCCURRENCE.
7. IF ANY BAT IS OBSERVED FLYING FROM A TREE OR A TREE THAT HAS BEEN CUT, TREE CLEARING ACTIVITIES WITHIN 150- FEET OF THE TREE SHALL BE SUSPENDED AND THE NYSDEC WILDLIFE STAFF SHALL BE NOTIFIED WITHIN TWENTY-FOUR (24) HOURS. A STOP WORK ORDER SHALL IMMEDIATELY BE ISSUED AND THE NYSDEC AND DPS STAFF CONSULTED BEFORE RESUMPTION OF WORK.

WETLANDS AND STREAMS, VEGETATION AND INVASIVE SPECIES

1. ALL NECESSARY PRECAUTIONS SHALL BE TAKEN TO PRECLUDE CONTAMINATION OF ANY WETLAND OR WATERWAY BY SUSPENDED SOLIDS, SEDIMENTS, FUELS, SOLVENTS, LUBRICANTS, EPOXY COATINGS, PAINTS, CONCRETE, LEACHATE OR ANY OTHER ENVIRONMENTALLY DELETERIOUS MATERIALS ASSOCIATED WITH THE PROJECT.
2. ALL CONSTRUCTION ACTIVITY, INCLUDING CLEARING OF VEGETATION, IS TO TAKE PLACE WITHIN THE PROJECT SITE AS DEPICTED ON PROJECT PLANS. NO CONSTRUCTION ACTIVITY IS TO TAKE PLACE WITHIN AREAS TO BE LEFT IN A NATURAL CONDITION. STAKING AND/OR FLAGGING CONSTRUCTION LIMITS SHALL OCCUR PRIOR TO ANY SITE DISTURBANCE.
3. ALL EQUIPMENT AND MACHINERY SHALL BE STORED AND SAFELY CONTAINED MORE THAN 100 FEET LANDWARD OF THE REGULATED WETLAND OR WATER BODY AT THE END OF EACH WORK DAY. THIS WILL SERVE TO AVOID THE INADVERTENT LEAKAGE OF DELETERIOUS SUBSTANCES INTO THE REGULATED AREA.
4. FUEL OR OTHER CHEMICAL STORAGE TANKS SHALL BE CONTAINED AND LOCATED AT ALL TIMES IN AN AREA MORE THAN 300 FEET LANDWARD OF ANY REGULATED WETLAND OR WATER BODY. IF THE ABOVE REQUIREMENT CANNOT BE MET, THEN THE STORAGE AREAS MUST BE DESIGNED TO COMPLETELY CONTAIN ANY AND ALL POTENTIAL LEAKAGE. SUCH A CONTAINMENT SYSTEM MUST BE APPROVED BY DEC STAFF IN WRITING PRIOR TO EQUIPMENT, MACHINERY OR TANK STORAGE.
5. ALL MOBILE EQUIPMENT, EXCLUDING DEWATERING PUMPS, MUST BE FUELED IN A LOCATION AT LEAST 100 FEET FROM THE TOP OF STREAM BANK, WETLAND, OR OTHER WATER BODY. DEWATERING PUMPS OPERATED CLOSER THAN 100 FEET FROM THE STREAM BANK, WETLAND, OR WATER BODY, MUST BE ON AN IMPERVIOUS SURFACE AND ABSORBENTS CAPABLE OF CONTAINING ANY LEAKAGE OF PETROLEUM PRODUCTS.
6. SPILLAGE OF FUELS, WASTE OILS, OTHER PETROLEUM PRODUCTS OR HAZARDOUS MATERIALS SHALL BE REPORTED TO THE DEC'S SPILL HOTLINE (1-800-457-7362) WITHIN TWO HOURS ACCORDING TO THE DEC SPILL REPORTING AND INITIAL NOTIFICATION REQUIREMENTS TECHNICAL FIELD GUIDANCE.
7. ALL EQUIPMENT USED WITHIN THE BED OR BANKS OF STREAMS, OR IN WETLANDS AND ADJACENT AREAS, MUST BE INSPECTED DAILY FOR LEAKS OF PETROLEUM, OTHER FLUIDS, OR CONTAMINANTS AND MAY ONLY ENTER A STREAM CHANNEL IF FOUND TO BE FREE OF ANY LEAKAGE. A SPILL KIT MUST BE ON SITE AND ANY LEAKS MUST BE STOPPED AND CLEANED UP IMMEDIATELY.
8. VISIBLY TURBID DISCHARGES FROM LAND CLEARING, SHALL NOT ENTER ANY SURFACE WATER BODY. ALL NECESSARY MEASURES SHALL BE IMPLEMENTED TO PREVENT ANY VISIBLE INCREASE IN TURBIDITY OR SEDIMENTATION DOWNSTREAM OF THE WORK SITE, INCLUDING BUT NOT LIMITED TO THE USE OF:
 - 8.1. APPROPRIATELY MAINTAINED UPLAND SETTLING BASINS;
 - 8.2. CRUSHED STONE, SAND, OR SILT SCREENING (MAXIMUM OPENING SIZE OF U.S. SIEVE NUMBER 20) TO FILTER TURBID WATERS;
 - 8.3. SILT-BAGS OR SIMILAR PRE-CONSTRUCTED STRUCTURE DESIGNED TO REMOVE SILT AND SEDIMENT PARTICLES BEFORE THEY ARE DISCHARGED; OR
 - 8.4. GRASSY UPLAND AREAS AT A SUFFICIENT DISTANCE FROM THE RECEIVING WATER BODY TO PREVENT A VISUALLY DISCERNIBLE TURBID DISCHARGE TO THE RECEIVING WATER.
9. AT LOCATIONS WHERE TEMPORARY WETLAND CROSSINGS ARE NECESSARY IMPACTS WILL BE AVOIDED THROUGH THE USE OF TIMBER MATS.
10. ALL DISTURBED SOILS WITHIN REGULATED FRESHWATER WETLANDS AND THE ASSOCIATED ADJACENT AREAS MUST BE SEEDED WITH A NATIVE SEED MIX OR CROPS CONSISTENT WITH EXISTING AGRICULTURAL USES. MULCH SHALL BE MAINTAINED UNTIL THE DISTURBED AREA IS PERMANENTLY STABILIZED. ADDITIONAL SEEDING SHALL BE COMPLETED AS NECESSARY TO ACHIEVE AN 80% VEGETATIVE COVER ACROSS ALL DISTURBED AREAS.
11. ANY DEBRIS OR EXCESS MATERIAL FROM CONSTRUCTION OF THE PROJECT SHALL BE COMPLETELY REMOVED FROM WETLANDS OR ADJACENT AREAS (UPLAND) AND RELOCATED TO A FACILITY DULY AUTHORIZED TO RECEIVE SUCH MATERIAL.
12. CLEARED VEGETATION AND SLASH FROM WETLANDS AND ADJACENT AREAS WILL NOT BE BURNED OR BURIED WITHIN THE WETLAND OR ADJACENT AREA. THE VEGETATION MUST BE DISPOSED OF OUTSIDE OF THE WETLAND AND ADJACENT AREA, BUT SLASH THAT IS CUT MAY BE LEFT IN PLACE (DROP AND LOP OR PILED IN DRY OR SEASONALLY SATURATED PORTIONS OF FRESHWATER WETLANDS AND 100-FOOT ADJACENT AREAS TO CREATE WILDLIFE BRUSH PILES).
13. TO CONTROL THE SPREAD OF INVASIVE INSECTS, THE CONTRACTOR WILL:
 - 13.1. ENSURE THAT ALL CONSTRUCTION EQUIPMENT (INCLUDING TIMBER MATS) IS CLEAN UPON ARRIVAL ON SITE, AND THAT EQUIPMENT UTILIZED IN AREAS WITH AN ABUNDANCE OF INVASIVE SPECIES ARE CLEANED PRIOR TO MOVING TO ANOTHER SITE.
 - 13.2. COORDINATE FOR SALE AND USE OF THE MERCHANTABLE TIMBER; AND PROVIDE UNMERCHANTABLE TIMBER AS FIREWOOD TO ADJACENT LANDOWNERS OR THE GENERAL PUBLIC PURSUANT TO THE DEC'S FIREWOOD RESTRICTIONS TO PROTECT FORESTS

FROM INVASIVE SPECIES FOUND IN 6 NYCRR PART 192.5;

- 13.3. MAKE SURE CREWS ARE TRAINED TO IDENTIFY THE ASIAN LONGHORNED BEETLE AND THE EMERALD ASH BORER AND ANY OTHER INSECTS THAT THE DEC IDENTIFIES AS A POTENTIAL PROBLEM. IF THESE INSECTS ARE ROUND, THEY MUST BE REPORTED TO THE DEC REGIONAL FORESTER, AND
- 13.4. COMPLY WITH SITE-SPECIFIC PLANS FOR MANAGEMENT OF JAPANESE KNOTWEED AND SPECIES AS DESCRIBED IN THE INVASIVE SPECIES CONTROL PLAN (ISCP).
14. IF A ONE-TIME CROSSING OF A STREAM OCCURS AS PART OF AN INSTALLATION OF A TEMPORARY BRIDGE AND A TIRE MAT IS USED, THE FOLLOWING RESTRICTIONS APPLY:
 - 14.1. THE MAT MUST FOLLOW THE CONTOUR OF THE STREAMBED AND ALLOW FOR A LOW FLOW CHANNEL AND NOT CHANGE THE FLOW PATH OF THE STREAM.
 - 14.2. THE MAT SHALL BE REMOVED IMMEDIATELY AFTER THE CROSSING OF THE STREAM OCCURS.
15. IF ANY TREES AND SHRUBS GROWING WITHIN 50 FEET OF STREAMS NEED TO BE CUT IN THE PROCESS OF CONSTRUCTING OVERHEAD POWER LINE CROSSINGS, THEY SHALL BE CUT OFF WITH AT LEAST TWO FEET OF THE STUMP REMAINING. STUMPS AND ROOT SYSTEMS SHALL NOT BE DAMAGED TO FACILITATE STUMP SPROUTING. TREES SHALL NOT BE FELLED INTO ANY STREAM OR ONTO THE IMMEDIATE STREAM BANK. ALL TREES AND SHRUBS CUT WITHIN THE 50 FOOT BUFFER AREA SHALL BE LEFT ON THE GROUND.
16. CLEARING OF NATURAL VEGETATION ALONG STREAMS AND WITHIN WETLANDS SHALL BE LIMITED TO THAT MATERIAL WHICH POSSES A HAZARD OR HINDERANCE TO THE CONSTRUCTION ACTIVITY. SNAGS WHICH PROVIDE SHELTER IN STREAMS FOR FISH SHALL NOT BE DISTURBED UNLESS THEY CAUSE SERIOUS OBSTRUCTIONS, SCOURING OR EROSION. TREES SHALL NOT BE FELLED INTO ANY STREAM OR ONTO THE IMMEDIATE STREAM BANK.
17. WITHIN 100 FEET OF STATE REGULATED WETLANDS AND 50 FEET OF OTHER WATER BODIES, REMOVE ONLY THE MINIMUM VEGETATION NECESSARY TO ALLOW CONSTRUCTION AND OPERATION OF THE FACILITY.
18. STREAMS AND WETLANDS WILL BE PROTECTED FROM INDIRECT IMPACTS DURING CONSTRUCTION BY UTILIZING VARIOUS EROSION AND SEDIMENT CONTROL MEASURES IN ACCORDANCE WITH APPROVED PROJECT STORMWATER POLLUTION PREVENTION PLAN (SWPPP). SUCH MEASURES WILL INCLUDE, BUT NOT BE LIMITED TO, SILT FENCES PLACED BETWEEN WATER RESOURCE BOUNDARIES AND CONSTRUCTION AREAS, EXPOSED SOIL WILL BE SEEDED AND/OR MULCHED, AS SOON AS PRACTICABLE, BUT IN ANY EVENT, NO LATER THAN THE END OF THE WORK DAY IN WHICH SITE DISTURBANCE OCCURS, TO ASSURE THAT EROSION AND SILTATION IS KEPT TO A MINIMUM ALONG STREAM AND WETLAND BOUNDARIES.
19. CONSTRUCTION WORK IN STREAMS WILL CONFORM TO APPROPRIATE TIMING RESTRICTIONS TO PROTECT IMPORTANT FISHERIES RESOURCES, DURING SPAWNING AND PRIMARY MIGRATION PERIODS. STREAMS SUBJECT TO SUCH RESTRICTIONS WILL BE DETERMINED IN THE FIELD BY REPRESENTATIVES OF THE DEC AND THE APPLICANT, PRIOR TO CONSTRUCTION. FOR COLD WATER FISHERIES IN THE PROJECT AREA, CONSTRUCTION WORK IN STREAMS WILL BE PROHIBITED BETWEEN OCTOBER 1 AND MAY 31 TO AVOID TROUT SPAWNING PERIODS. FOR WARM WATER FISHERIES, CONSTRUCTION WORK IN STREAMS WILL BE PROHIBITED BETWEEN MARCH 1 AND JULY 15. HOWEVER, ONCE INSTALLED, SUCH CROSSINGS CAN BE USED BY CONSTRUCTION VEHICLES THROUGHOUT THE DURATION OF PROJECT CONSTRUCTION. ANY EXCEPTIONS TO THESE PROHIBITED PERIODS REQUIRE PRIOR APPROVAL BY DPS STAFF, IN CONSULTATION WITH DEC.
20. ANY DISRUPTION TO DEC REGULATED WETLANDS WILL BE MINIMIZED. DEC'S FIELD REPRESENTATIVE WILL NOTIFY THE DPS STAFF REPRESENTATIVE AND THE APPLICANT'S REPRESENTATIVE OF ANY ACTIVITIES THAT VIOLATE OR MAY VIOLATE EITHER THE TERMS OF THE ARTICLE 10 CERTIFICATE OR THE ENVIRONMENTAL CONSERVATION LAW. DPS AND DEC STAFF'S FIELD REPRESENTATIVES WILL WORK COOPERATIVELY TO DETERMINE WHETHER STOP WORK AUTHORITY WILL BE EXERCISED, OR WHETHER TO DIRECT THE APPLICANT TO TAKE ACTION TO FURTHER MINIMIZE IMPACTS TO STREAMS AND WETLANDS.
21. RESTRICTED ACTIVITIES PERTAIN TO A BUFFER ZONE OF 300 FEET ON EITHER SIDE OF THE BOUNDARIES OF WATER-RELATED RESOURCES (STREAMS, WETLANDS, SPRINGS, WELLS, DRAINAGE, ETC.) AND INCLUDE THE FOLLOWING RESTRICTIONS:
 - A. NO DEPOSITION OF SLASH WITHIN IDENTIFIABLE STREAM CHANNELS OR WOOD CHIPS WITHIN 25 FEET OF WETLANDS;
 - B. NO UNNECESSARY REMOVAL OF WOODY VEGETATION OR DEGRADATION OF STREAM BANKS;
 - C. NO EQUIPMENT WASHING OR REFUELING EXCEPT AS SPECIFIED IN THE FINAL CONSTRUCTION DRAWINGS;
 - D. AND NO STORAGE MIXING OR HANDLING OF ANY PETROLEUM OR CHEMICAL MATERIALS IN OPEN CONTAINERS.
 - E. REFUELING OF EQUIPMENT MUST UTILIZE SECONDARY CONTAINMENT MEASURES.

CLEARING METHODS

1. TYPE I - CLEARING CONSISTS OF CLEARING THE DESIGNATED AREAS OF ALL WOOD PLANTS, INCLUDING DESIRABLE LOW-GROWING SPECIES. ALL PLANTS WILL BE CUT AS CLOSE TO THE GROUND AS PRACTICABLE, AND AFTER CUTTING NO PLANT WILL EXCEED SIX (6) INCHES ABOVE GROUND LINE. TYPE I CLEARING WILL BE UTILIZED IN CIRCUMSTANCES WHERE WOODY PLANTS WOULD HINDER ACCESS AND CONSTRUCTION ACTIVITIES (I.E. IN CONNECTION WITH CLEARING ACCESS ROADS, WORK AREAS, AND COLLECTION LINE ROUTES).
2. TYPE II - CLEARING CONSISTS OF CLEARING THE DESIGNATED AREAS OF ANY WOODY PLANTS SPECIES WHICH HAVE THE POTENTIAL TO VIOLATE MINIMUM CLEARANCE DISTANCE. ALL GROWTH WILL BE CUT AS CLOSE TO THE GROUND AS PRACTICABLE, BUT IN NO CASE WILL AFTER-CUTTING HEIGHT EXCEED SIX (6) INCHES ABOVE GROUND LINE, UNLESS OTHERWISE DIRECTED BY THE ENVIRONMENTAL MONITOR (EM).
3. REASONABLE CARE WILL BE TAKEN, INsofar AS IS PRACTICAL, TO RETAIN DESIRABLE SPECIES FOUND WITHIN TYPE I CLEARING ZONES. THE ENVIRONMENTAL MONITOR (EM) WILL MAKE A FIELD DETERMINATION AS TO WHETHER SUCH RETENTION WOULD IMPOSE AN UNREASONABLE BURDEN ON CLEARING OR CONSTRUCTION ACTIVITIES.

WOOD/SLASH DISPOSAL METHODS

1. TYPE A - CONSISTS OF REMOVING ALL WOODY DEBRIS FROM THE PROPERTY.
2. TYPE B - CONSISTS OF THE REMOVAL OF ALL LOGS FROM THE PROPERTY. BRUSH/SLASH SHOULD BE CHIPPED AND SPREAD WITHIN THE LIMITS OF DISTURBANCE.
3. TYPE C - LOGS SHALL BE PLACED IN PILES IN DESIGNATED STORAGE AREAS AS SHOWN, OR AT THE EDGE OF THE LIMITS OF DISTURBANCE. BRUSH/SLASH SHOULD BE CHIPPED AND SPREAD WITHIN THE LIMITS OF DISTURBANCE.
4. TYPE D - CONSISTS OF DROPPING LOPPING TREES SO THAT THE SLASH LIES AS CLOSE TO THE GROUND AS PRACTICABLE, WITH BRANCHES AND LIMB WOOD NOT EXCEEDING AN AVERAGE DEPTH OF TWENTY-FOUR (24) INCHES. INCLUDING WETLAND AND STREAMS AREAS, TYPE D WOOD DISPOSAL WILL ADHERE TO THE FOLLOWING ADDITIONAL CONDITIONS INCLUDED:
 - 4.1. ONLY A SELECTIVE PORTION OF VEGETATION, AS NEEDED TO PREVENT THE BLOCKING OF FLOW AND THE TRAPPING OF DEBRIS, IS TO BE REMOVED FROM THE WATER COURSE AND FLOODWAY. ALL CUTTINGS (REGARDLESS OF LOCATIONS) ARE TO BE CUT AND BUCKED TO LIE NEAR GROUND LEVEL. HOWEVER WHERE TREE ROOT BASES ARE ATTACHED TO THE STREAM BANK, THEY WILL BE LEFT IN PLACES. THE REMAINDER OF THE TREE WILL BE CUT FROM THE BASE PRIOR TO REMOVAL.

DANGER TREES

1. A DANGER TREE IS ANY TREE ROOTED OUTSIDE OF A ROW THAT DUE TO ITS PROXIMITY AND PHYSICAL CONDITION (I.E., MORALITY, LEAN, DECAY, CAVITIES, CRACKS, WEAK BRANCHING, ROOT LIFTING, OR OTHER INSTABILITY), POSSES A PARTICULAR DANGER TO A CONDUCTOR OR OTHER KEY COMPONENT OF THE FACILITY.
2. ALL DANGER TREES WILL BE REMOVED AT THE TIME OF THE INITIAL CLEARING AND AS PART OF THE NORMAL CLEARING ACTIVITIES. THE SLASH FROM THESE DANGER TREES WILL BE DISPOSED OF IN ACCORDANCE WITH THE SLASH DISPOSAL METHOD DESIGNATED FOR THE WORK AREA ADJOINING THE AREA FROM WHICH THE DANGER TREES HAVE BEEN REMOVED.

PROCEDURE FOR OFF-SITE REMOVAL OF STUMPS, CHIPS, AND SLASH

1. WHERE OFF-SITE REMOVAL OF STUMPS, CHIPS, OR SLASH IS NECESSARY, ALL MATERIALS WILL BECOME THE PROPERTY OF THE CONTRACTOR. IN ALL CASES, ALL MATERIAL THAT IS REMOVED FROM THE SITE WILL BE DISPOSED ON IN AN ENVIRONMENTALLY-ACCEPTABLE MANNER AND IN COMPLIANCE WITH ALL APPLICABLE RULES AND REGULATIONS INCLUDING 6 NYCRR PART 192 AND ALL OTHER INVASIVE SPECIES REGULATIONS.
2. THE CONTRACTOR WILL PROVIDE HOFFMAN FALLS WIND LLC WITH A DESCRIPTION AND THE LOCATION OF ALL PROPOSED OFF-SITE DISPOSAL SITES PRIOR TO THE START OF THE PROJECT. THE ENVIRONMENTAL MONITOR (EM) WILL INSPECT ALL PROPOSED OFF-SITE DISPOSAL SITES TO ENSURE THAT THEY ARE SUITABLE AND WILL NOTIFY DPS STAFF.

Westwood Surveying & Engineering

Phone (952) 937-5150 12701 Whitewater Drive, Suite #300
Fax (952) 937-5822 Minnetonka, MN 55343
TollFree (888) 937-5150 ww-pc.com

Westwood Surveying and Engineering, P.C.

PREPARED FOR:

Hoffman Falls Wind LLC

90 State Street, Suite 700
Albany, NY 12207

REVISIONS:

#	DATE	COMMENT	BY	CHK	APR
A	08/25/2023	30% CIVIL DESIGN	HR	DK	AL
B	12/29/2023	60% CIVIL DESIGN	HR	HR	AL

Hoffman Falls Wind Project

Madison County, New York

General Notes - 2

ISSUE FOR PERMIT

DATE: 12/29/2023

SHEET: C719

REV:

B

The background of the page is a dark red color with a complex pattern of lighter red contour lines, resembling a topographic map. A vertical dashed red line runs down the center of the page, with a solid red dot located near the bottom of this line.

Appendix F

Post-Construction Maintenance
Inspection Forms

Stormwater Pond/Wetland Operation, Maintenance and Management Inspection Checklist

Project _____
 Location: _____
 Site Status: _____

 Date: _____
 Time: _____

 Inspector: _____

Maintenance Item	Satisfactory/ Unsatisfactory	Comments
1. Embankment and emergency spillway (Annual, After Major Storms)		
1. Vegetation and ground cover adequate		
2. Embankment erosion		
3. Animal burrows		
4. Unauthorized planting		
5. Cracking, bulging, or sliding of dam		
a. Upstream face		
b. Downstream face		
c. At or beyond toe		
downstream		
upstream		
d. Emergency spillway		
6. Pond, toe & chimney drains clear and functioning		
7. Seeps/leaks on downstream face		
8. Slope protection or riprap failure		
9. Vertical/horizontal alignment of top of dam "As-Built"		

Maintenance Item	Satisfactory/ Unsatisfactory	Comments
10. Emergency spillway clear of obstructions and debris		
11. Other (specify)		
2. Riser and principal spillway (Annual)		
Type: Reinforced concrete _____ Corrugated pipe _____ Masonry _____		
1. Low flow orifice obstructed		
2. Low flow trash rack. a. Debris removal necessary		
b. Corrosion control		
3. Weir trash rack maintenance a. Debris removal necessary		
b. corrosion control		
4. Excessive sediment accumulation insider riser		
5. Concrete/masonry condition riser and barrels a. cracks or displacement		
b. Minor spalling (<1")		
c. Major spalling (rebars exposed)		
d. Joint failures		
e. Water tightness		
6. Metal pipe condition		
7. Control valve a. Operational/exercised		
b. Chained and locked		
8. Pond drain valve a. Operational/exercised		
b. Chained and locked		
9. Outfall channels functioning		
10. Other (specify)		

Maintenance Item	Satisfactory/ Unsatisfactory	Comments
3. Permanent Pool (Wet Ponds) (monthly)		
1. Undesirable vegetative growth		
2. Floating or floatable debris removal required		
3. Visible pollution		
4. Shoreline problem		
5. Other (specify)		
4. Sediment Forebays		
1. Sedimentation noted		
2. Sediment cleanout when depth < 50% design depth		
5. Dry Pond Areas		
1. Vegetation adequate		
2. Undesirable vegetative growth		
3. Undesirable woody vegetation		
4. Low flow channels clear of obstructions		
5. Standing water or wet spots		
6. Sediment and / or trash accumulation		
7. Other (specify)		
6. Condition of Outfalls (Annual , After Major Storms)		
1. Riprap failures		
2. Slope erosion		
3. Storm drain pipes		
4. Endwalls / Headwalls		
5. Other (specify)		
7. Other (Monthly)		
1. Encroachment on pond, wetland or easement area		

Maintenance Item	Satisfactory/ Unsatisfactory	Comments
2. Complaints from residents		
3. Aesthetics a. Grass growing required		
b. Graffiti removal needed		
c. Other (specify)		
4. Conditions of maintenance access routes.		
5. Signs of hydrocarbon build-up		
6. Any public hazards (specify)		
8. Wetland Vegetation (Annual)		
1. Vegetation healthy and growing Wetland maintaining 50% surface area coverage of wetland plants after the second growing season. (If unsatisfactory, reinforcement plantings needed)		
2. Dominant wetland plants: Survival of desired wetland plant species Distribution according to landscaping plan?		
3. Evidence of invasive species		
4. Maintenance of adequate water depths for desired wetland plant species		
5. Harvesting of emergent plantings needed		
6. Have sediment accumulations reduced pool volume significantly or are plants "choked" with sediment		
7. Eutrophication level of the wetland.		
8. Other (specify)		

Comments:

Actions to be Taken:

The background of the page is a dark red topographic map with intricate contour lines. A dashed red line runs vertically through the center, ending in a solid red dot near the bottom.

Appendix G

Contractor Certification and
Inspection, Maintenance, and
SWPPP Amendment Forms

**APPENDIX F
CONSTRUCTION SITE INSPECTION
AND MAINTENANCE LOG BOOK**

**STATE POLLUTANT DISCHARGE ELIMINATION SYSTEM FOR CONSTRUCTION
ACTIVITIES**

SAMPLE CONSTRUCTION SITE LOG BOOK

Table of Contents

- I. Pre-Construction Meeting Documents
 - a. Preamble to Site Assessment and Inspections
 - b. Pre-Construction Site Assessment Checklist

- II. Construction Duration Inspections
 - a. Directions
 - b. Modification to the SWPPP

I. PRE-CONSTRUCTION MEETING DOCUMENTS

Project Name _____
Permit No. _____ **Date of Authorization** _____
Name of Operator _____
Prime Contractor _____

a. Preamble to Site Assessment and Inspections

The Following Information To Be Read By All Person’s Involved in The Construction of Stormwater Related Activities:

The Operator agrees to have a qualified inspector¹ conduct an assessment of the site prior to the commencement of construction² and certify in this inspection report that the appropriate erosion and sediment controls described in the SWPPP have been adequately installed or implemented to ensure overall preparedness of the site for the commencement of construction.

Prior to the commencement of construction, the Operator shall certify in this site logbook that the SWPPP has been prepared in accordance with the State’s standards and meets all Federal, State and local erosion and sediment control requirements. A preconstruction meeting should be held to review all of the SWPPP requirements with construction personnel.

When construction starts, site inspections shall be conducted by the qualified inspector at least every 7 calendar days. The Operator shall maintain a record of all inspection reports in this site logbook. The site logbook shall be maintained on site and be made available to the permitting authorities upon request.

Prior to filing the Notice of Termination or the end of permit term, the Operator shall have a qualified inspector perform a final site inspection. The qualified inspector shall certify that the site has undergone final stabilization³ using either vegetative or structural stabilization methods and that all temporary erosion and sediment controls (such as silt fencing) not needed for long-term erosion control have been removed. In addition, the Operator must identify and certify that all permanent structures described in the SWPPP have been constructed and provide the owner(s) with an operation and maintenance plan that ensures the structure(s) continuously functions as designed.

1 Refer to “Qualified Inspector” inspection requirements in the current SPDES General Permit for Stormwater Discharges from Construction Activity for complete list of inspection requirements.
2 “Commencement of construction” means the initial removal of vegetation and disturbance of soils associated with clearing, grading or excavating activities or other construction activities.
3 “Final stabilization” means that all soil-disturbing activities at the site have been completed and a uniform, perennial vegetative cover with a density of eighty (80) percent has been established or equivalent stabilization measures (such as the use of mulches or geotextiles) have been employed on all unpaved areas and areas not covered by permanent structures.

b. Pre-construction Site Assessment Checklist

(NOTE: Provide comments below as necessary)

1. Notice of Intent, SWPPP, and Contractors Certification:

Yes No NA

- Has a Notice of Intent been filed with the NYS Department of Conservation?
- Is the SWPPP on-site? Where? _____
- Is the Plan current? What is the latest revision date? _____
- Is a copy of the NOI (with brief description) onsite? Where? _____
- Have all contractors involved with stormwater related activities signed a contractor's certification?

2. Resource Protection

Yes No NA

- Are construction limits clearly flagged or fenced?
- Important trees and associated rooting zones, on-site septic system absorption fields, existing vegetated areas suitable for filter strips, especially in perimeter areas, have been flagged for protection.
- Creek crossings installed prior to land-disturbing activity, including clearing and blasting.

3. Surface Water Protection

Yes No NA

- Clean stormwater runoff has been diverted from areas to be disturbed.
- Bodies of water located either on site or in the vicinity of the site have been identified and protected.
- Appropriate practices to protect on-site or downstream surface water are installed.
- Are clearing and grading operations divided into areas <5 acres?

4. Stabilized Construction Access

Yes No NA

- A temporary construction entrance to capture mud and debris from construction vehicles before they enter the public highway has been installed.
- Other access areas (entrances, construction routes, equipment parking areas) are stabilized immediately as work takes place with gravel or other cover.
- Sediment tracked onto public streets is removed or cleaned on a regular basis.

5. Sediment Controls

Yes No NA

- Silt fence material and installation comply with the standard drawing and specifications.
- Silt fences are installed at appropriate spacing intervals
- Sediment/detention basin was installed as first land disturbing activity.
- Sediment traps and barriers are installed.

6. Pollution Prevention for Waste and Hazardous Materials

Yes No NA

- The Operator or designated representative has been assigned to implement the spill prevention avoidance and response plan.
- The plan is contained in the SWPPP on page _____
- Appropriate materials to control spills are onsite. Where? _____

II. CONSTRUCTION DURATION INSPECTIONS

a. Directions:

Inspection Forms will be filled out during the entire construction phase of the project.

Required Elements:

- 1) On a site map, indicate the extent of all disturbed site areas and drainage pathways. Indicate site areas that are expected to undergo initial disturbance or significant site work within the next 14-day period;
- 2) Indicate on a site map all areas of the site that have undergone temporary or permanent stabilization;
- 3) Indicate all disturbed site areas that have not undergone active site work during the previous 14-day period;
- 4) Inspect all sediment control practices and record the approximate degree of sediment accumulation as a percentage of sediment storage volume (for example, 10 percent, 20 percent, 50 percent);
- 5) Inspect all erosion and sediment control practices and record all maintenance requirements such as verifying the integrity of barrier or diversion systems (earthen berms or silt fencing) and containment systems (sediment basins and sediment traps). Identify any evidence of rill or gully erosion occurring on slopes and any loss of stabilizing vegetation or seeding/mulching. Document any excessive deposition of sediment or ponding water along barrier or diversion systems. Record the depth of sediment within containment structures, any erosion near outlet and overflow structures, and verify the ability of rock filters around perforated riser pipes to pass water; and
- 6) Immediately report to the Operator any deficiencies that are identified with the implementation of the SWPPP.

SITE PLAN/SKETCH

Inspector (print name)

Date of Inspection

Qualified Inspector (print name)

Qualified Inspector Signature

The above signed acknowledges that, to the best of his/her knowledge, all information provided on the forms is accurate and complete.

Maintaining Water Quality

Yes No NA

- Is there an increase in turbidity causing a substantial visible contrast to natural conditions at the outfalls?
- Is there residue from oil and floating substances, visible oil film, or globules or grease at the outfalls?
- All disturbance is within the limits of the approved plans.
- Have receiving lake/bay, stream, and/or wetland been impacted by silt from project?

Housekeeping

1. General Site Conditions

Yes No NA

- Is construction site litter, debris and spoils appropriately managed?
- Are facilities and equipment necessary for implementation of erosion and sediment control in working order and/or properly maintained?
- Is construction impacting the adjacent property?
- Is dust adequately controlled?

2. Temporary Stream Crossing

Yes No NA

- Maximum diameter pipes necessary to span creek without dredging are installed.
- Installed non-woven geotextile fabric beneath approaches.
- Is fill composed of aggregate (no earth or soil)?
- Rock on approaches is clean enough to remove mud from vehicles & prevent sediment from entering stream during high flow.

3. Stabilized Construction Access

Yes No NA

- Stone is clean enough to effectively remove mud from vehicles.
- Installed per standards and specifications?
- Does all traffic use the stabilized entrance to enter and leave site?
- Is adequate drainage provided to prevent ponding at entrance?

Runoff Control Practices

1. Excavation Dewatering

Yes No NA

- Upstream and downstream berms (sandbags, inflatable dams, etc.) are installed per plan.
- Clean water from upstream pool is being pumped to the downstream pool.
- Sediment laden water from work area is being discharged to a silt-trapping device.
- Constructed upstream berm with one-foot minimum freeboard.

Runoff Control Practices (continued)

2. Flow Spreader

Yes No NA

- Installed per plan.
- Constructed on undisturbed soil, not on fill, receiving only clear, non-sediment laden flow.
- Flow sheets out of level spreader without erosion on downstream edge.

3. Interceptor Dikes and Swales

Yes No NA

- Installed per plan with minimum side slopes 2H:1V or flatter.
- Stabilized by geotextile fabric, seed, or mulch with no erosion occurring.
- Sediment-laden runoff directed to sediment trapping structure

4. Stone Check Dam

Yes No NA

- Is channel stable? (flow is not eroding soil underneath or around the structure).
- Check is in good condition (rocks in place and no permanent pools behind the structure).
- Has accumulated sediment been removed?.

5. Rock Outlet Protection

Yes No NA

- Installed per plan.
- Installed concurrently with pipe installation.

Soil Stabilization

1. Topsoil and Spoil Stockpiles

Yes No NA

- Stockpiles are stabilized with vegetation and/or mulch.
- Sediment control is installed at the toe of the slope.

2. Revegetation

Yes No NA

- Temporary seedings and mulch have been applied to idle areas.
- 4 inches minimum of topsoil has been applied under permanent seedings

Sediment Control Practices

1. Silt Fence and Linear Barriers

Yes No NA

- Installed on Contour, 10 feet from toe of slope (not across conveyance channels).
 - Joints constructed by wrapping the two ends together for continuous support.
 - Fabric buried 6 inches minimum.
 - Posts are stable, fabric is tight and without rips or frayed areas.
- Sediment accumulation is ___% of design capacity.

Sediment Control Practices (continued)

2. Storm Drain Inlet Protection (Use for Stone & Block; Filter Fabric; Curb; or, Excavated; Filter Sock or Manufactured practices)

Yes No NA

- Installed concrete blocks lengthwise so open ends face outward, not upward.
 - Placed wire screen between No. 3 crushed stone and concrete blocks.
 - Drainage area is 1acre or less.
 - Excavated area is 900 cubic feet.
 - Excavated side slopes should be 2:1.
 - 2" x 4" frame is constructed and structurally sound.
 - Posts 3-foot maximum spacing between posts.
 - Fabric is embedded 1 to 1.5 feet below ground and secured to frame/posts with staples at max 8-inch spacing.
 - Posts are stable, fabric is tight and without rips or frayed areas.
 - Manufactured insert fabric is free of tears and punctures.
 - Filter Sock is not torn or flattened and fill material is contained within the mesh sock.
- Sediment accumulation ___% of design capacity.

3. Temporary Sediment Trap

Yes No NA

- Outlet structure is constructed per the approved plan or drawing.
 - Geotextile fabric has been placed beneath rock fill.
 - Sediment trap slopes and disturbed areas are stabilized.
- Sediment accumulation is ___% of design capacity.

4. Temporary Sediment Basin

Yes No NA

- Basin and outlet structure constructed per the approved plan.
 - Basin side slopes are stabilized with seed/mulch.
 - Drainage structure flushed and basin surface restored upon removal of sediment basin facility.
 - Sediment basin dewatering pool is dewatering at appropriate rate.
- Sediment accumulation is ___% of design capacity.

Note: Not all erosion and sediment control practices are included in this listing. Add additional pages to this list as required by site specific design. All practices shall be maintained in accordance with their respective standards.

Construction inspection checklists for post-development stormwater management practices can be found in Appendix F of the New York Stormwater Management Design Manual.

SUBCONTRACTOR CERTIFICATION

STORMWATER POLLUTION PREVENTION PLAN

SPDES Project Number:	
Project Title:	
Project Location:	
Project Operator:	

As a subcontractor, you are required to comply with the Stormwater Pollution Prevention Plan (SWPPP) for any work that you perform on-site. Any person or group who violates any condition of the SWPPP may be subject to substantial penalties or loss of contract. You are encouraged to advise each of your employees working on this project of the requirements of the SWPPP. A copy of the SWPPP is available for your review at the office trailer. Each subcontractor engaged in activities at the construction site that could impact stormwater must be identified and sign the following certification statement:

“I hereby certify under penalty of law that I understand and agree to comply with the terms and conditions of the SWPPP and agree to implement any corrective actions identified by the qualified inspector during a site inspection. I also understand that the owner or operator must comply with the terms and conditions of the most current version of the New York State Pollutant Discharge Elimination System (“SPDES”) general permit for stormwater discharges from construction activities and that it is unlawful for any person to cause or contribute to a violation of water quality standards. Furthermore, I am aware that there are significant penalties for submitting false information that I do not believe to be true, including the possibility of fine and imprisonment of knowing violations.”

This certification is hereby signed in reference to the above named project:

Company:	
Address:	
Telephone Number:	
Description of Work:	
Trained Contractor Signature:	
Title:	
Date:	

The background of the page is a dark red topographic map with intricate contour lines. A dashed red line runs vertically through the center, ending in a solid red dot near the bottom.

Appendix H

Endangered Species and Cultural
Resource Information and
Correspondence